

CS CLEVELAND
STEEL TOOL

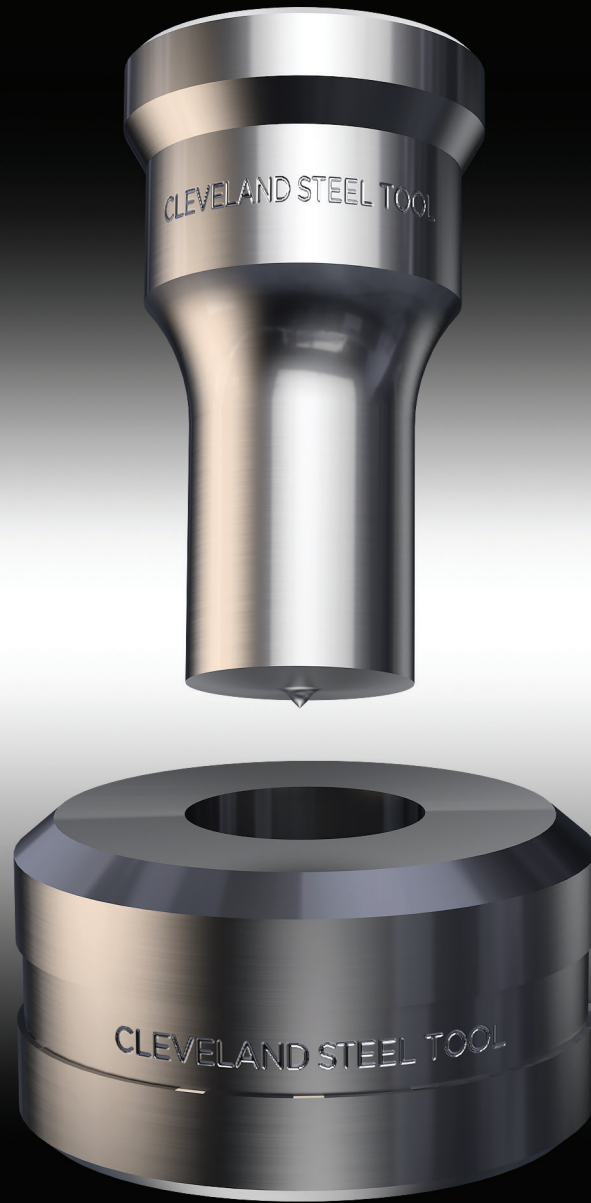

Catalog 103
clevelandsteeltool.com
800-446-4402

Welcome To Cleveland Steel Tool!



For nearly 110 years, we've been a Cleveland Ohio, family owned business providing solutions to the metalworking marketplace.

In addition to our core punch, die and shear blade product line, we offer Ironworker machines, magnetic drills and annular cutters, steel saws and saw blades, and a portable punching unit for those applications where a large machine just won't work.

Technical expertise is what sets us apart in the industry, so tell us what your application is and we'll design a solution to fit your needs. We can reverse engineer an existing tool, custom design a new tool for you to use in your shop or, if you'd prefer, we'll fabricate the parts for you in ours.

Our focus is on providing solutions to our customers. Whether it's same day shipment on stock products, reverse engineering, custom tooling or contract manufacturing, you will receive the highest quality products, made by our extremely skilled team.

Cleveland Steel Tool...since 1908, dedicated to meeting the needs and exceeding the expectations of our customers.



474 East 105th Street
Cleveland, OH 44108
800-446-4402
216-681-7400 • Fax 216-681-7009
sales@clevelandsteeltool.com
www.clevelandsteeltool.com



Punches, Dies and Shear Blades

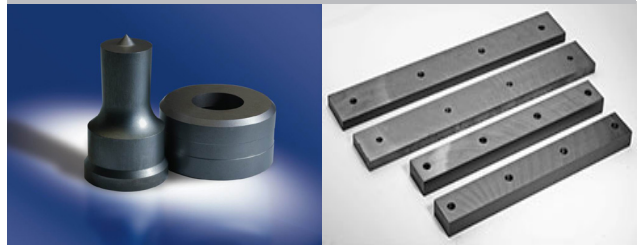

Shop our huge inventory or take advantage of 24 hour turnaround on non-stock Punch and Die sizes. We can provide any shear blade, and also have hundreds in stock.

Custom Tooling

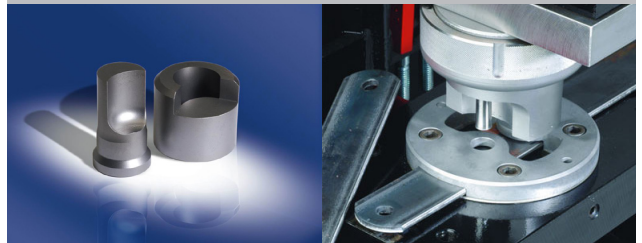

Customize your Ironworker with Die Sets, Special Shapes and Applications.

Machinery



Ironworker machines, Portable Punching Units, Magnetic Drills, Steel Saws and Accessories.

Contract Manufacturing



If it's Steel, Aluminum or Bronze, talk to us first. We can help.

Table of Contents

General Information

Ordering Information	6
A Typical Punch Set-Up	6
Ensure Long Life of Tooling	6
Clearance Guide	7
Punching Tonnage Guide	7

Punch and Die Styles

Headed Punch Styles	8
Standard Die Styles	10
Non-Headed Punch Styles	12
Alternate Die Styles	13
28XX Punches and Dies	14

Punch Options

Shapes	15
Keyways	15
Punch Faces	16
Punch Styles	16

Die Options

Locating Spots and Grooves	17
Special Tools for Angle and I-Beam	17
Eccentric/Offset Die Hole Position	17

Miscellaneous Tooling

Countersink Tools	18
Extra Length Punches	18
Marker Punches and Center Punches	18
Ripping Punch	19
Corner Rounding Tooling	19
Lattice Bar (Trim and Part) Tooling	19
Picket Tooling	19
Standard Coupling Nuts	20
Punch Stems	20
Die Holders	21
Tooling to Adapt Machines	21
Metal Culvert Tooling	22
Leaf Spring Tooling	23
Punch Cross Reference Chart	56
Die Cross Reference Chart	57
Custom Tooling	58

Portable Punching Machine	60
Magnetic Drilling Machines	61
Annular Cutters	62
Steel Saws and Saw Blades	63
Cleveland Steel Tool Ironworkers	64
Hydraulic Power	68
Ironworker Accessories	69
Contract Manufacturing Services	71

Tooling Specifications for:

Cleveland Steel Tool™ Ironworkers	24
Brobo™ Ironworkers	49
Buffalo™ Ironworkers	26
Clousing™/Metal Muncher™ Ironworkers	28
Controlled Automation™ Machines	29
Dvorak™ Ironworkers	47
Edwards™ Ironworkers	30
Ficep™ Ironworkers	32
Franklin™ Ironworkers	33
Geka™ Ironworkers	34
Hawthorne™ Ironworkers	30
Hendley & Whittemore™ Ironworkers	36
Hill-Acme™/Kling™ Ironworkers	37
HMI™ (Hydraulic Machines Inc.™) Ironworkers	38
Hougen-Ogura™ Machines	39
Metal Muncher™	28
Mubea™ Ironworkers	40
Nitto Kohki™ Machines	41
Peddinghaus™ Machines	42
Piranha™ Ironworkers	45
Pittsburgh™ Ironworkers	30
Rotex™	Call for more information
Scotchman™ Ironworkers	47
Spartan™/Brobo™ Ironworkers	49
Springwater™	Call for more information
Sunrise™ Ironworkers	51
Uni-Hydro™ Ironworkers	52
Voortman™	Call for more information
W.A. Whitney™ Machines	53

Machine Tooling Chart

Baileigh™	Model	Punch	Die
	All Models	SUN30P	SUN45D
		SUN40P	SUN51D
		SUN60P	SUN80D
Bully™ (Davco™)	Model	Punch	Die
	All Models	219	417
	Oversize	228	419
Durma™	Model	Punch	Die
	IW10	221	417
	IW45	219	417
	IW55	221	417
	IW80	221	417
	Oversize	228	421
Dvorak™	Model	Punch	Die
	All Models	DVP	DVD
	Oversize	DVP2	DVD2
Enerpac™	Model	Punch	Die
	25 Ton	HUSPCH	HUSDIE
	35 Ton	212	405
	50 Ton	219	417
Gairu™	Model	Punch	Die
	MF10	216	408
	MF16	221	417
	MF20	221	417
	Suprema 11	216	408
	Suprema 13	216	408
	Suprema 16	221	417
	Suprema 20	221	417
Ironcrafter™	Model	Punch	Die
	30-30	221	417
	40-40	62/63	48/47
	50-50	221	417
	60	221	417
	70-70	221	417
	95-95	221	417
	120-120	228	419
	150-150	228	419
	Oversize	237/28XX	490/28XX
Kingsland™	Model	Punch	Die
	45XM	228	417
	50XA	228	417
	60DP	228	417
	60P625	228	417
	60XS	228	417
	65XA	228	417
	75DP	228	417
	75P625	228	417

Machine Tooling Chart

Kingsland™ (Continued)	Model	Punch	Die
	75XS	228	417
	95DP	228	417
	95P625	228	417
	95XS	228	417
	125DP	228	417
	125P625	228	417
	125XS	228	417
	175P625	228	417
	175XS	228	417
	Compact 50	221	419
	Compact 65	221	419
	J14/A or B	228	417
	J18/GXA or B	228	417
	J21/GXA or B	228	417
	J25/GXA or B	228	417
Shark	228	417	
Ultima Models	228	417	
Oversize	237	422	
Lehman™	Model	Punch	Die
	All Models	BNP	BND
Marvel™	Model	Punch	Die
	MSIW60D	221	417
	MSIW66S	228	419
	MSIW71D	228	419
	MSIW93D	228	419
	MSIW126D	228	419
	MSIW126DX	228	419
	MSIW192DX	228	419
Metal Pro™	Model	Punch	Die
	MP 4000	DVP	DVD
	MP 4000FS	DVP	DVD
	MP 4500FS	DVP	DVD
	Oversize	DVPOS	420
Omera™	Model	Punch	Die
	13-45S	221	417
	16-70S	228	419
	20-95S	228	419
	115-35S	221	417
	M-10	221	417
	OM1/2	221	417
Promoco/Omes™	Model	Punch	Die
	CH70	221	417
	CH100	221	417
Rogers™	Model	Punch	Die
	All Models	BNP	BND

General Information

ORDERING INFORMATION

Delivery

Cleveland Steel Tool has a huge inventory of standard punches and dies in stock and ready for immediate shipment. Our stock tools can be shipped the same day. Non-stock sizes of standard tooling will ship within 24 hours (round, oblong, square, hexagon and rectangle).

Custom Tooling

Cleveland Steel Tool specializes in the rapid turnaround of your custom items. Send us a drawing or a sample and we'll manufacture your part to your specifications. Or call us at 800-446-4402 and talk to our application specialists. **Non-stock and custom tooling is not returnable.**

Help Us Help You When Ordering

At Cleveland Steel Tool, we've built our reputation on exceeding our customer's expectations for quality, delivery and value. To help us make sure you get the right tools, we may ask for the following information:

- Machine manufacturer and model number
- Style of punch and die (if not known, have a sample for measurement)
- Use of keyways and/or spots to position shapes
- Type and thickness of material being punched
- Hole size (Note: hole size must be slightly larger than item being passed through material)

TYPICAL PUNCH SET-UP

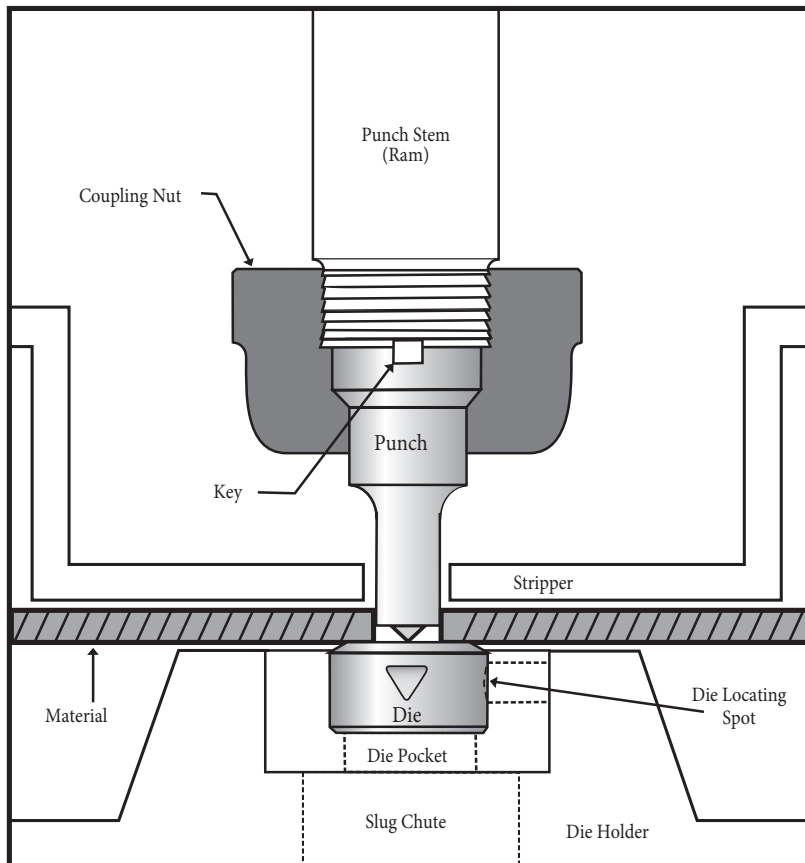

Punch: The male (usually upper) portion of a punching set-up determines the hole size. The hole (punch) must be slightly larger than the bolt or rod passing through it.

Die: The female or bottom portion of the punching set-up. The hole of the die is slightly larger than the punch used. Clearance is determined by the type and thickness of material being punched. See Clearance Guide on the next page.

Stripping: Pulling the punch out of the material after punching.

Ensure Long Life of Tooling:

Every tool manufactured by Cleveland Steel Tool is made of the highest grade of tool steel. To maximize performance and tool life:

1. Maintain and frequently check alignment of the punch with the die.
2. Check that the stripper is properly positioned to prevent tilting of the work piece when the punch is retracted.
3. Coupling nuts and punch stems must be properly tightened to hold tooling securely.
4. Lubricate with Motor Honey® or STP® Oil Treatment whenever possible.
5. Replace worn tooling immediately.

WARNING: It is the responsibility of the user to set up and use machine and tooling in accordance with OSHA and ANSI B11.5 safety standards. Do not allow unqualified personnel to set up or operate machines. Use extreme care at all times.

CAUTION: Extreme pressures are generated in all metal punching applications. Use safety guards and follow all machine manufacturers safety precautions.

General Information

CLEARANCE GUIDE

Clearance is the amount of extra space required in the hole of the die to allow the punch and slug to pass through to make the hole in the material. Clearance is determined by the type and thickness of the material being punched.

Clearance For Punching Mild Steel

Mild Steel Thickness	Clearance
16 gauge (.0598") and lighter	.006"
15 gauge (.0673) through 13 gauge (.0897)	.010"
3/32" up to 5/32"	1/64"
3/16" through 15/32"	1/32"
1/2" through 23/32"	1/16"
3/4" and over	3/32"
1" and over	1/8"

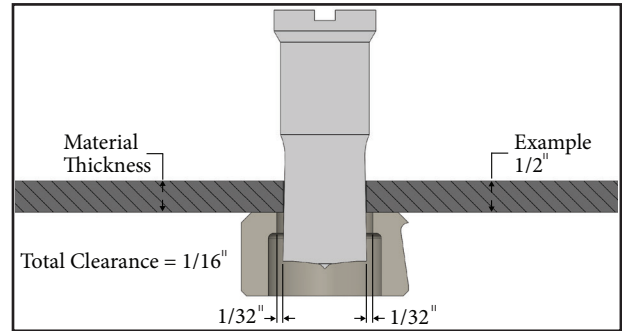

NOTE: The thickness of the material should not exceed the punch diameter.

Clearance Guide For Punching Other Material

Material	% of thickness
Soft Aluminum	10%
1/2 Hard Brass	11%
1/2 Hard Copper	12%
.50C Steel	18%
Stainless Steel	18%

EXAMPLE: To punch 1/2" (.500) mild steel
1/16" total clearance is needed

EXAMPLE: To punch 1/4" stainless
.250 X 18% = .045 clearance needed



Scan here for our on-line Die Clearance Calculator

PUNCHING TONNAGE GUIDE

For punching mild steel, approximately 65,000 psi

Round Holes

The following formula is the Cleveland Steel Tool recommended equation for computing the approximate tonnage required to punch a single round hole in mild steel.

$$\text{Punch Diameter} \times \text{Material Thickness} \times 80 = \text{Tonnage Required}$$

EXAMPLE: To punch a 1/2" (.500) hole through 1/4" (.250) thick mild steel:
.500 x .250 x 80 = 10 tons

Shaped Holes

The following formula is the Cleveland Steel Tool recommended equation for computing the approximate tonnage required to punch a single shaped hole in mild steel.

$$\frac{1}{3} \text{ of Perimeter} \times \text{Material Thickness} \times 80 = \text{Tonnage Required}$$

EXAMPLE: To punch a 9/16" x 1" rectangular hole through 1/2" (.500) thick mild steel:
(.33 x 3.125) x .500 x 80 = 41 tons

Tonnage Multiplier

For punching materials with different tensile strength, first determine the tonnage required for mild steel above, and then use the multiplier to the right.

Material Multiplier	
Aluminum	.38
Brass	.70
Copper	.56
Steel (mild)	1.00
Steel (50% carbon)	1.50
Steel Cold Drawn	1.20
Stainless Steel (303)	1.50



Scan here for our on-line Tonnage Calculator

Example: To punch a 1/2" (.500) hole through 1/4" (.250) stainless:
10 tons x 1.5 = 15 tons required for 1/4" stainless

Headed Punch Styles

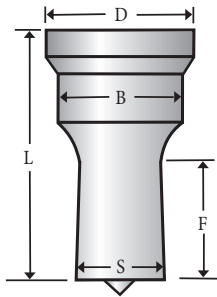

- D** = Head Diameter
- B** = Body Diameter
- L** = Overall length of punch
(not including center point)
- S** = Punch size (hole size)
- F** = Effective working length of punch
(determined by punch diameter)

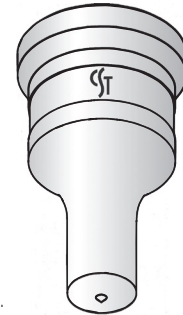

Note: All standard punches are supplied with a back taper unless otherwise specified. The thickness of the material should not exceed the punch diameter being used.

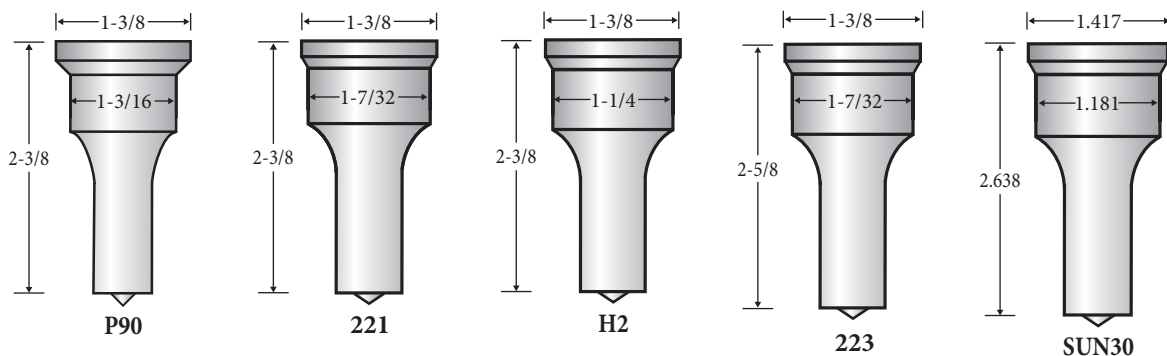
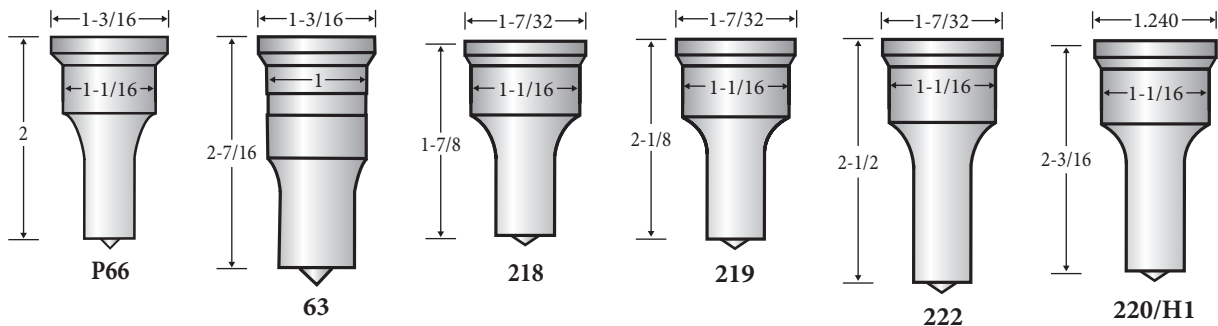
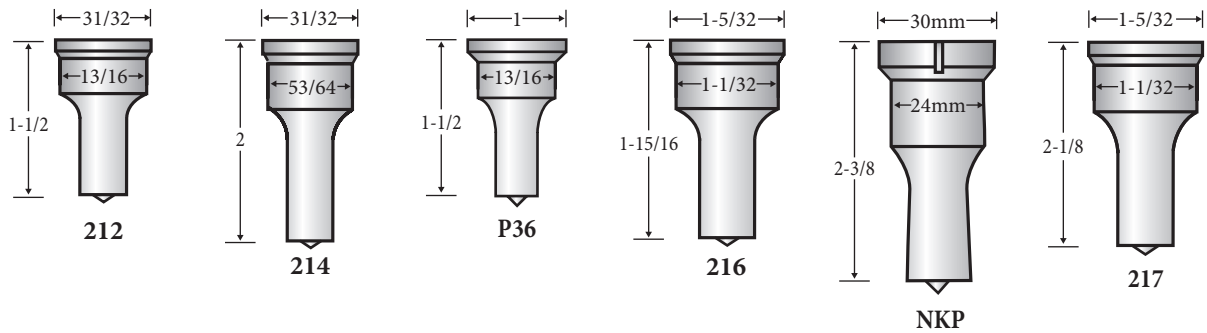
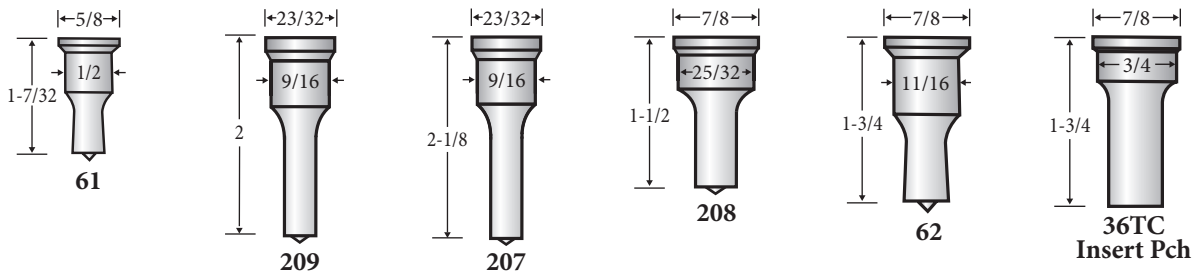

Headed Punch Styles

Headed Punch Styles

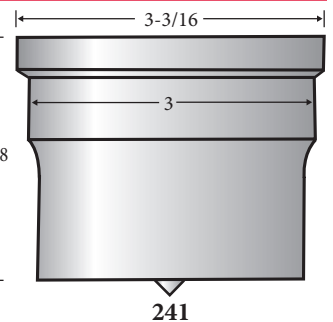
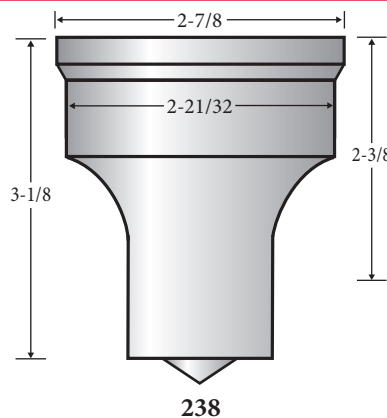
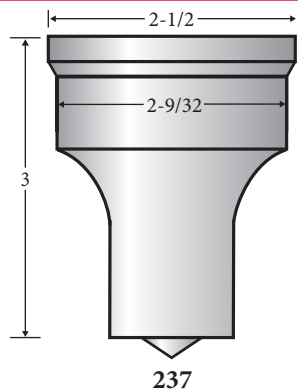
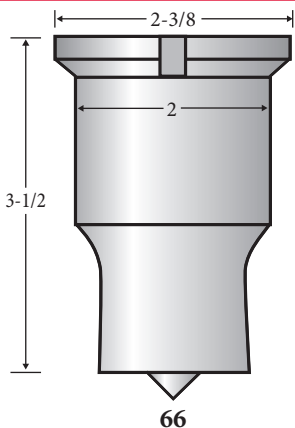
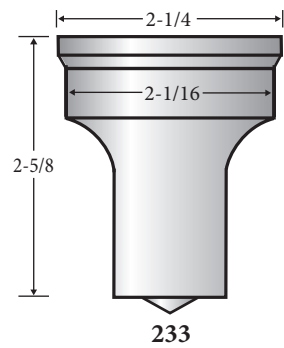
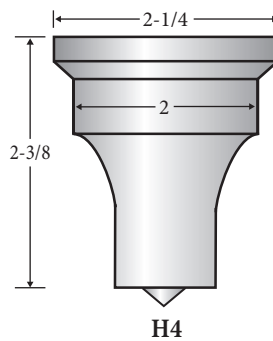
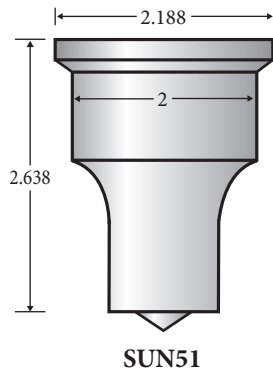
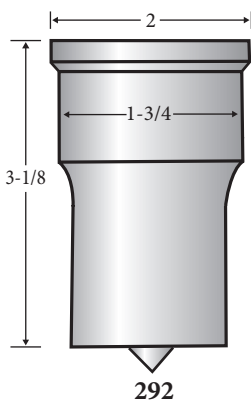
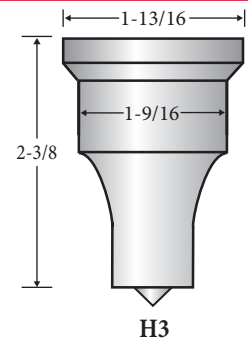
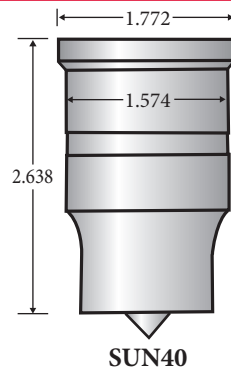
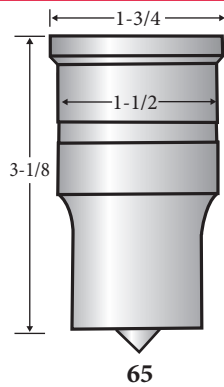
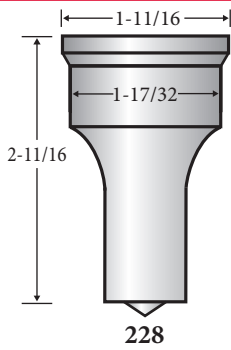
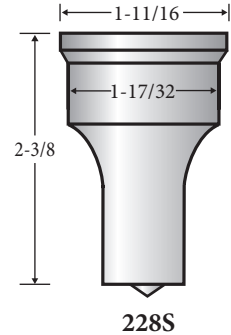
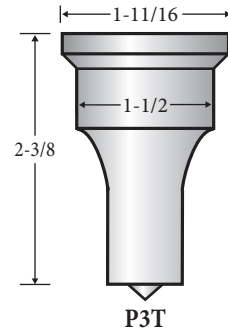
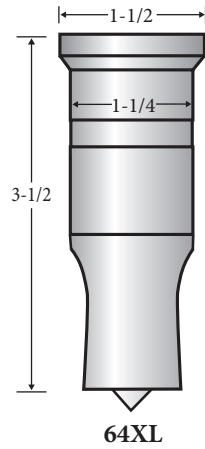
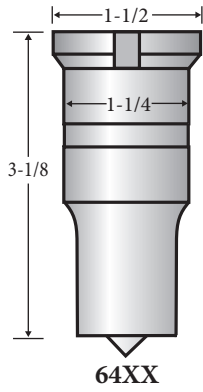
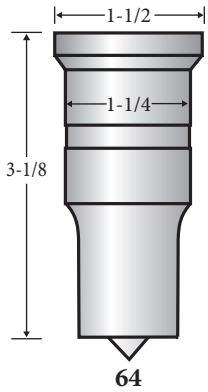

Standard Die Styles

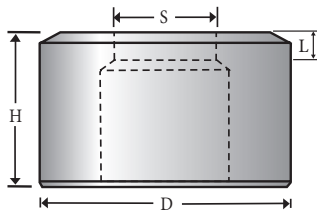

S = Size
L = Land
H = Height
D = Diameter

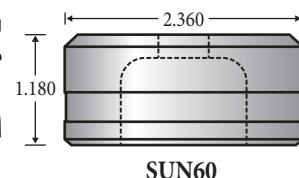
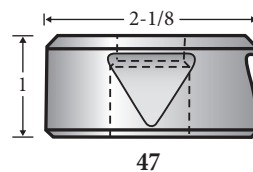
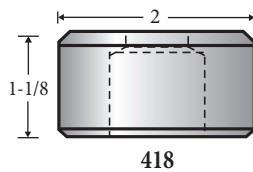
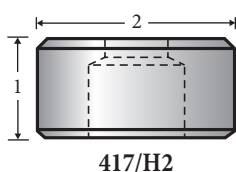
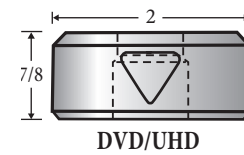
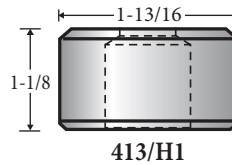
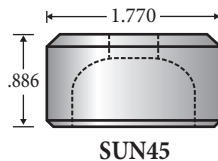
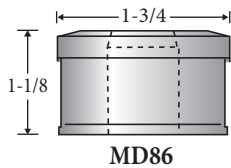
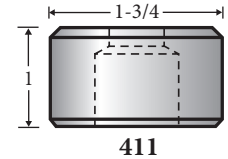
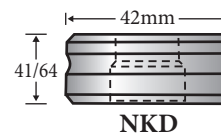
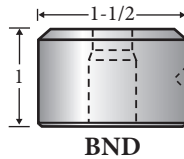
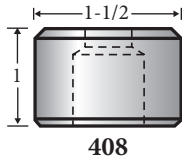
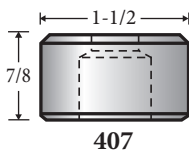
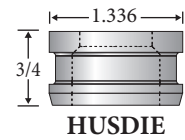
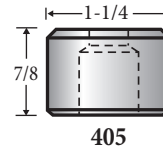
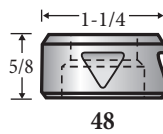
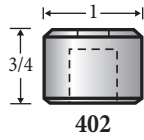
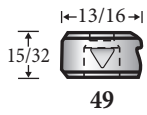
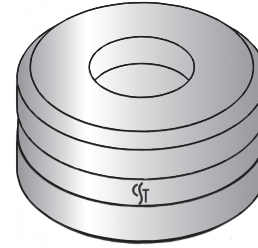

Standard Die Styles

Standard Die Styles

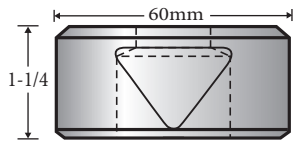

60mm

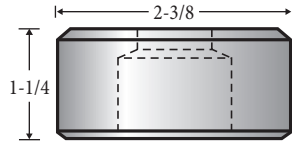

419

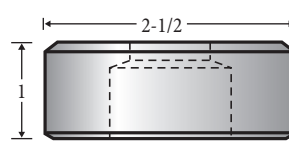

291

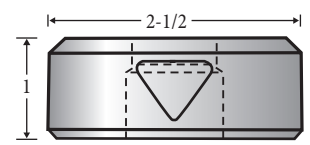

UHD2

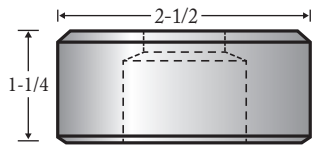

420/H3

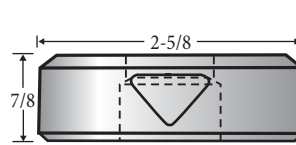

DVD2

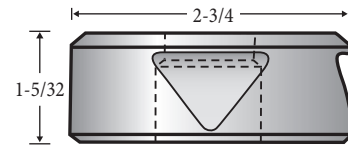

46

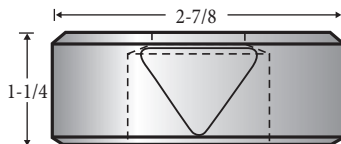

421

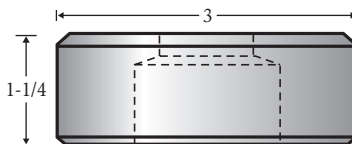

422

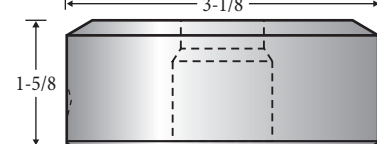

H4

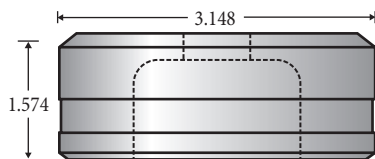

SUN80

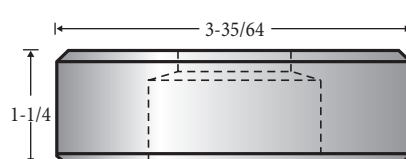

490

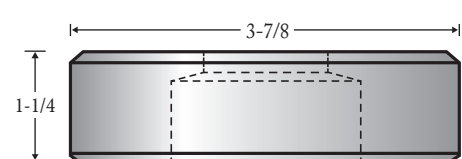

423

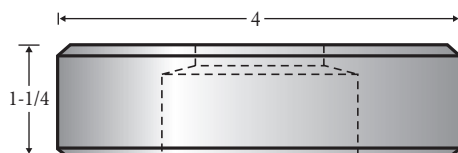

424

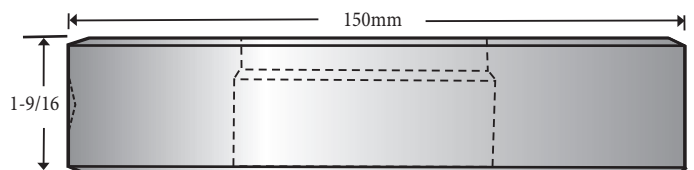

H5

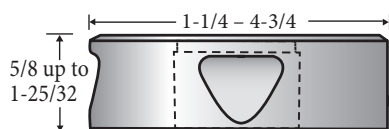

28XX

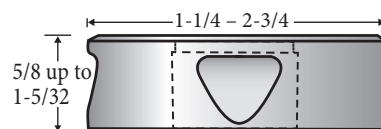

36TC

Non-Headed Punch Styles

HOUGEN - OGURA PUNCHES

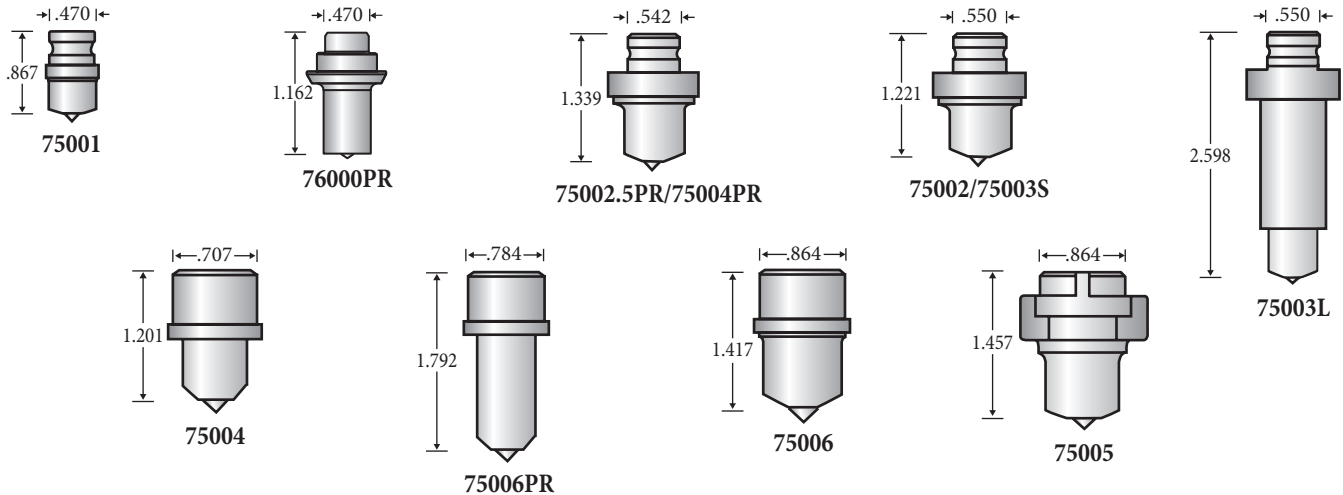

STRAIGHT SHANK PUNCHES

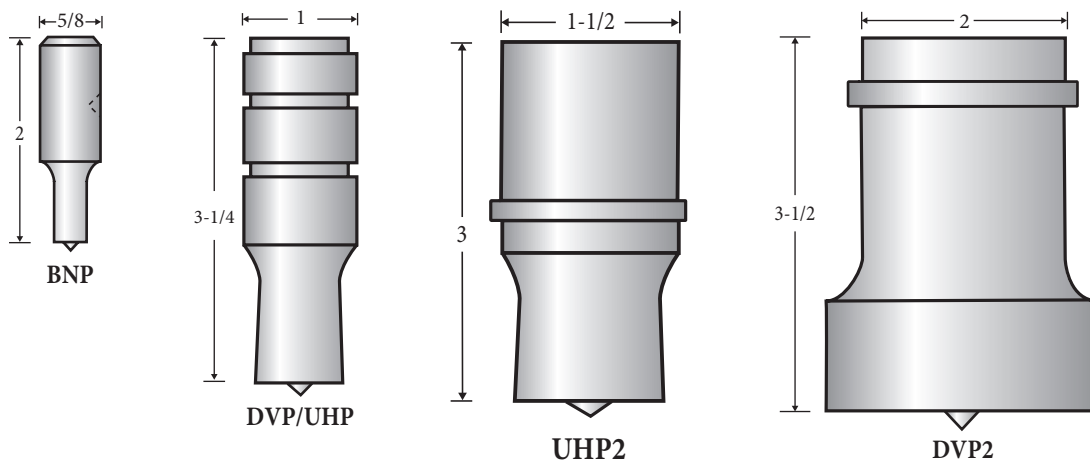

SHOULDER PUNCHES

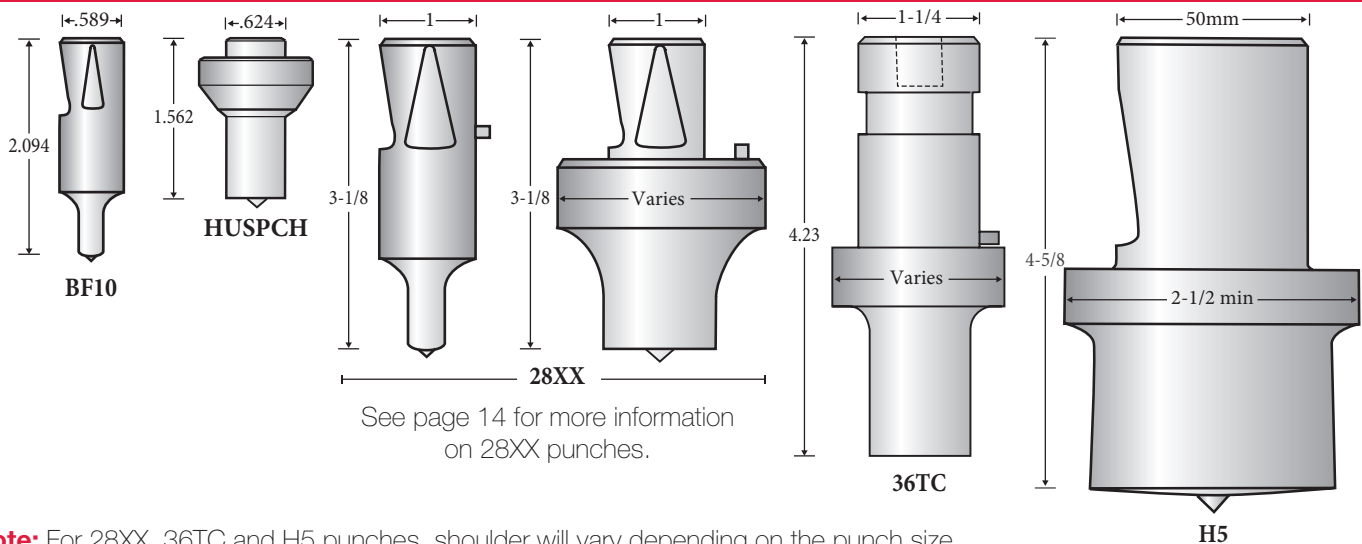

Note: For 28XX, 36TC and H5 punches, shoulder will vary depending on the punch size.

Alternate Die Styles

HOUGEN - OGURA DIES

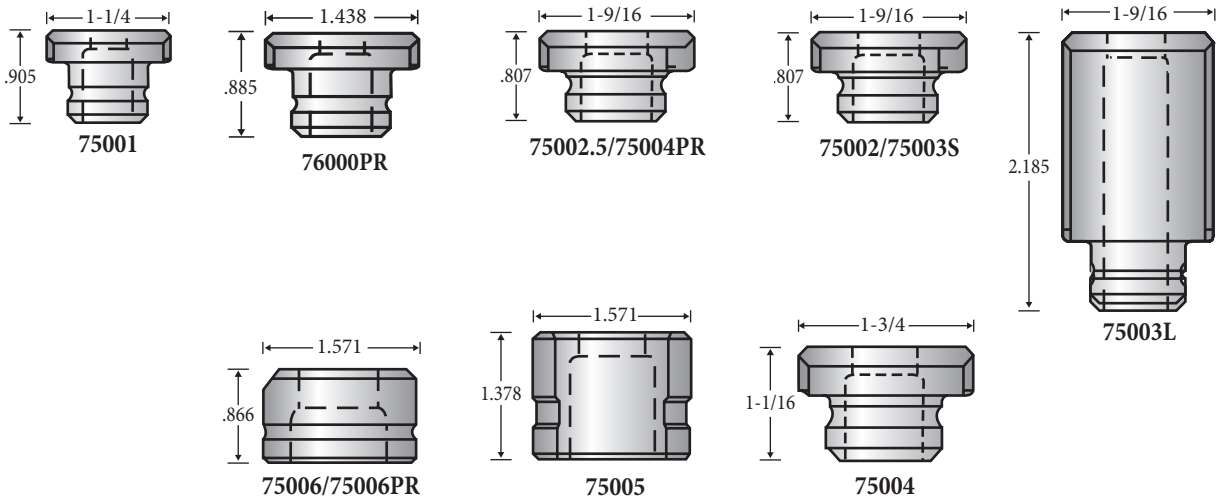

CULVERT DIES

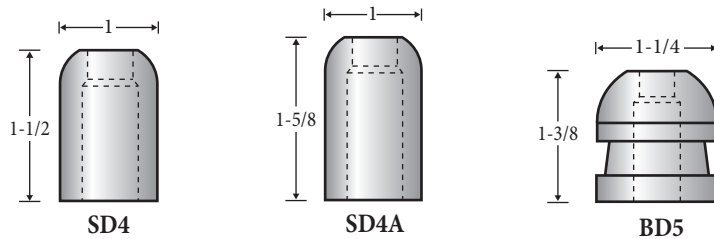

BUFFALO DIES

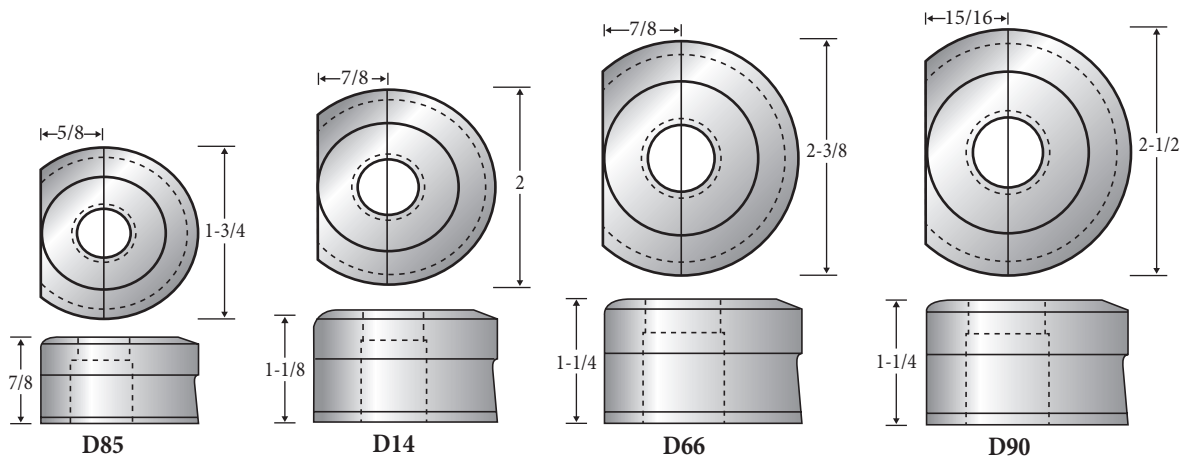

28XX Punches and Dies

PUNCHES

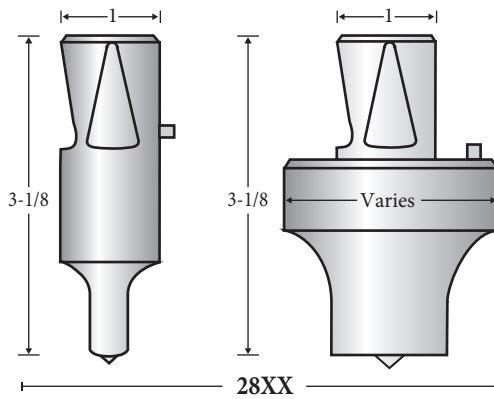

28XX Punches		
Shoulder	Max Round Size	Max Square Size
1"	1"	11/16"
1-1/2"	1-1/2"	1-1/16"
2"	2"	1-13/32"
2-1/2"	2-1/2"	1-3/4"
3"	3"	2-1/8"
3-1/2"	3-1/2"	2-15/32"
4"	4"	2-13/16"
4-1/2"	4-1/2"	3-3/16"
5"	5"	3-17/32"

Shoulder size on 28XX style punches will vary depending on hole size, from a straight shank (no shoulder) punch to a 5 inch shoulder for punching up to 5 inch round holes. Consult the chart above for the shoulder size for your hole requirements.

DIES

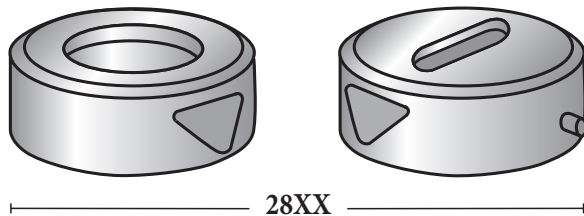

28XX Dies			
Outside Diameter (D)	Height (H)	Max Round size	Max Square size
1-1/4"	5/8"	.824	.582
2-1/8"	7/8"	1.465	1.036
2-3/4"	1-5/32"	2.012	1.423
3-3/4"	1-5/32"	3.012	2.130
4-3/4"	1-5/32"	4.012	2.837
5-3/4"	1-25/32"	5.012	3.562

Outside Diameter and Height of 28XX Dies varies according to hole size. The chart shows recommended OD and Height to maintain die wall thickness.

Punch Options — Shapes and Keyways

STANDARD SHAPES

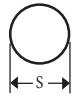

Round

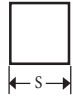

Square

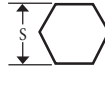

Hex

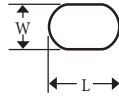

Oblong

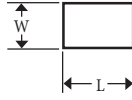

Rectangle

Non-stock sizes and shapes of stock style tooling can be shipped in 24 hours.

NON-STANDARD SHAPES

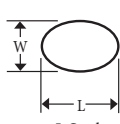

J-Oval (Ellipse)

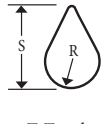

T-Teardrop

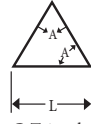

G-Triangle

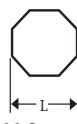

M-Octagon

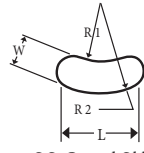

OO-Curved Oblong

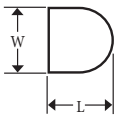

D-Half Oblong

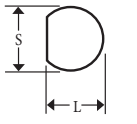

Q-Flatted Round

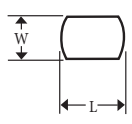

P-Double Flatted Round

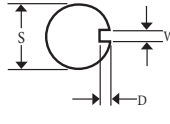

C-Knockout

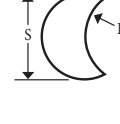

R-Corner Round

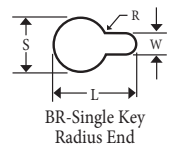

BR-Single Key Radius End

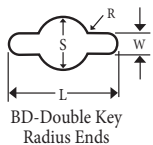

BD-Double Key Radius Ends

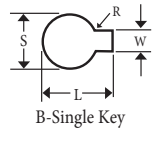

B-Single Key

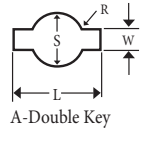

A-Double Key

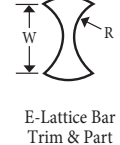

E-Lattice Bar Trim & Part

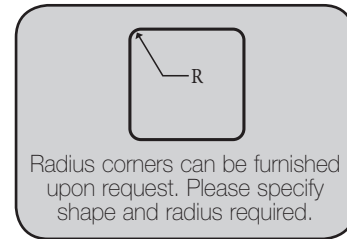

STANDARD KEYWAYS

Cleveland Steel Tool recommends the use of Keyways for positive alignment of shaped punches. Different ironworker machines use different size and style keyways. Some common styles, shapes and sizes are stocked with keyways, but the necessary keyway can be added to any punch upon request.

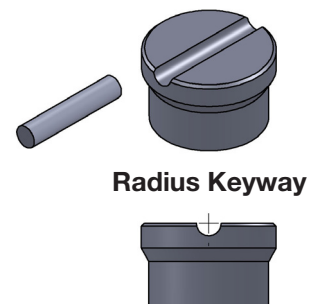
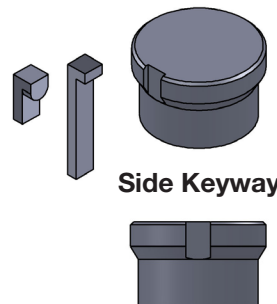
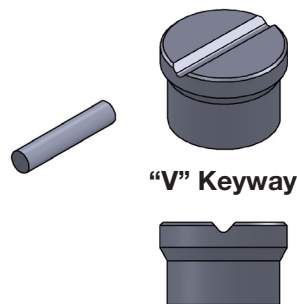
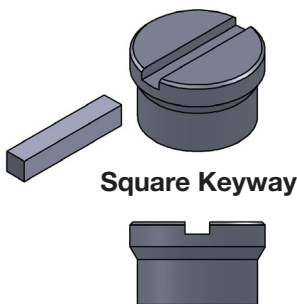

STANDARD KEYWAY POSITIONS

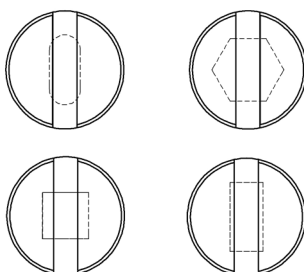

Keyway Sizes

1/4" x 1/8"
"V" Groove
2mm x 4mm
3mm x 6mm
Custom sizes

OPTIONAL KEYWAY POSITIONS

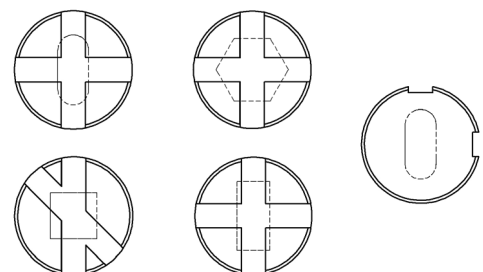

Punch Options

CHOICE OF PUNCH FACES

Cleveland Steel Tool offers a Crown Face with Center Point as our standard punch face. Other punch faces are available for special applications, including reducing distortion, and reducing tonnage requirements.

**CST Standard
Crown Face
Center Point**

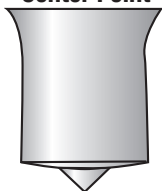

This standard face includes a center point for alignment and a crown face to reduce chipping of the cutting edge in heavy punching applications.

Full Crown

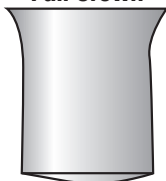

This face reduces the chipping of cutting edges in heavy punching applications. The center point is removed for height clearance between the punch and the material.

**Flat Face
Center Point**

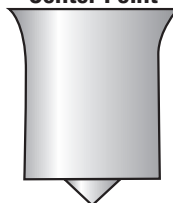

This face includes a center point for alignment and a flat face to reduce distortion when punching repetitive holes in a narrow flat bar such as a fence or railing.

Flat Face

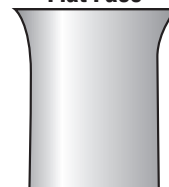

This face is used when punching thin material to reduce deformation of punched material caused by a center point. This punch is also used when the slug is being retained.

"Y" Shear

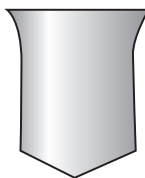

This face is used mainly on thicker material to reduce tonnage.

**"Y" Shear with
Center Point**



This face is also used on thicker material to reduce tonnage but has a center point for alignment.

"Z" Shear

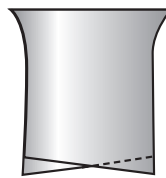

This face is used for thin material to reduce tonnage and distortion. Must be used on material 16 gauge thick or lighter.

**Concave
Shear**

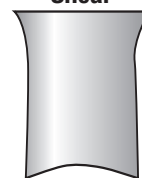

This face reduces tonnage and distortion on material 1/4" thick and less. This punch will break if used on thicker material.

PUNCH STYLES

These punch styles can be made to your exact specifications. Please provide the style number you require including all dimensions.

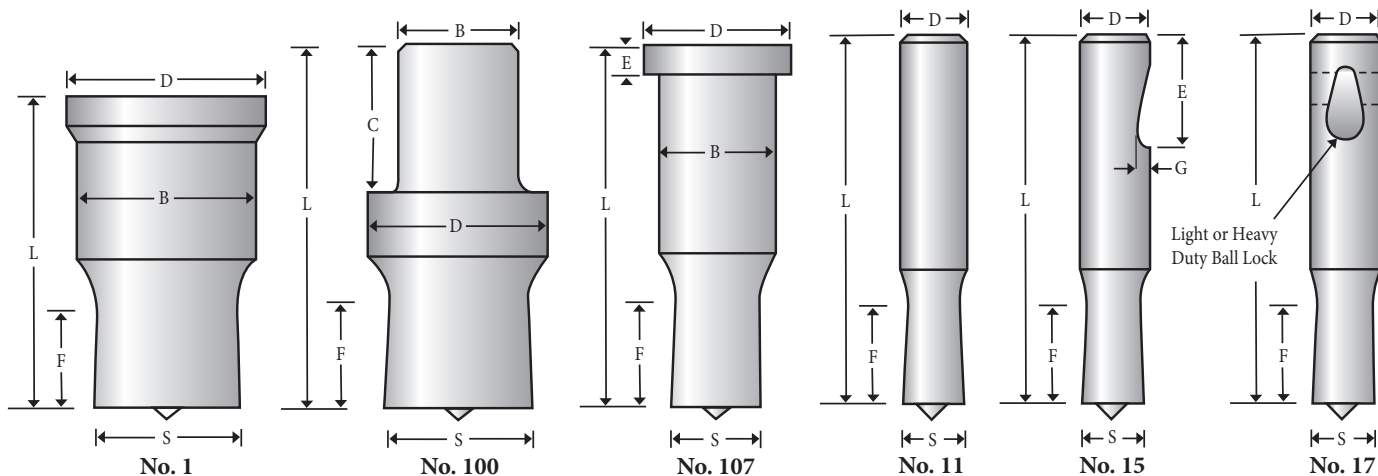



Die Options

LOCATING SPOTS AND GROOVES

Cleveland Steel Tool offers a Whistle Spot as a standard locating spot on shaped dies. Other Locating Spots and Grooves are available to fit your machine.

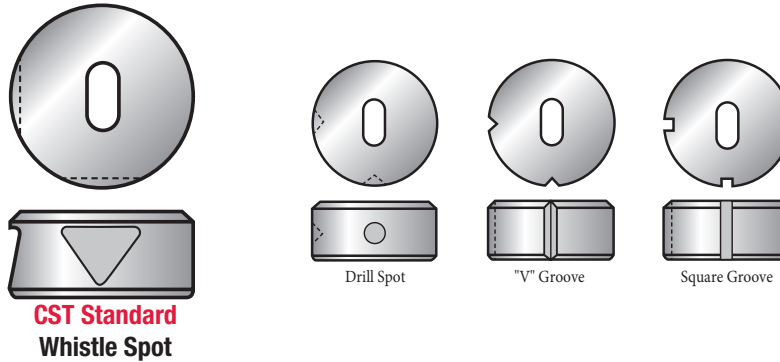

SPECIAL TOOLS FOR ANGLE AND I-BEAM

Flat Sided Dies

A Flat Sided Die allows a hole to be punched closer to the Gauge Line on Angle Iron.

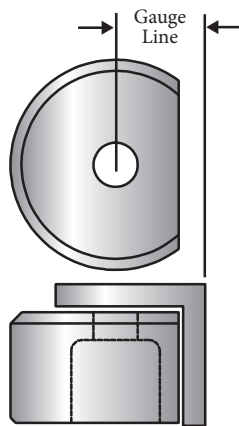

Bevel Top Dies

Bevel Top Dies and Bevel Corrugated Dies are used when punching structural "I" beams, to maintain vertical punch and die alignment and to prevent slipping of punched material.

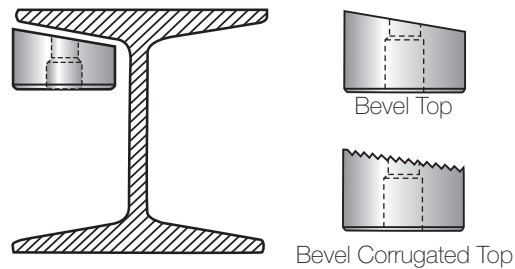

Eccentric/Offset Punch

Using a Punch with an Offset Hole allows the hole to be punched closer to a desired gauge line. The punch must have the same offset as the die.

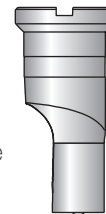

ECCENTRIC/OFFSET DIE HOLE POSITION

Using a Die with an Offset Hole allows the hole to be punched closer to a desired gauge line. A minimum 1/4" wall thickness is required.

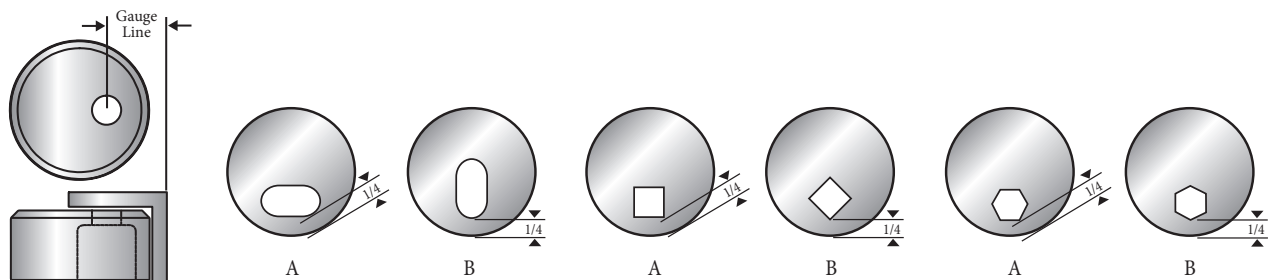

Miscellaneous Tooling

COUNTERSINK TOOLS

Countersink tooling produces a countersunk hole for flat head screws. Please indicate screw size, material thickness, punch and die style and type of countersink required.

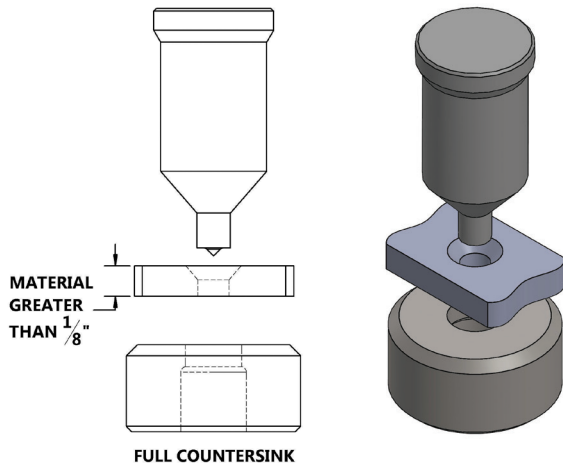

FULL COUNTERSINK

Material 1/8" and greater will typically not deform with countersink operation.

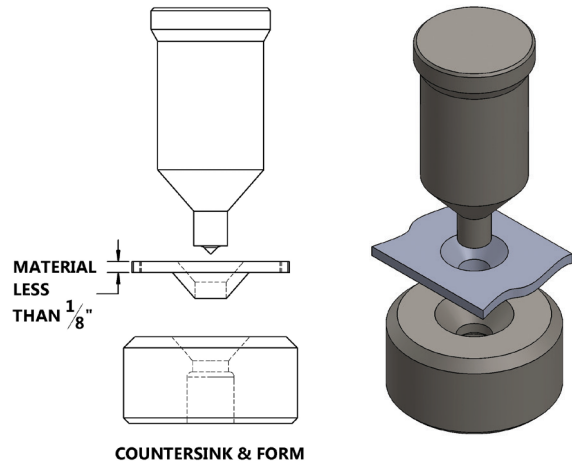

COUNTERSINK & FORM

Material under 1/8" will deform with countersink operation.

EXTRA LENGTH PUNCHES

Some applications require extra length to be added to the "F" dimension (working end of the punch) or the "Body" dimension for clearance punching leg up or closer to the flange. For special orders, please specify the length of the "F" dimension or "Body" of Punch.

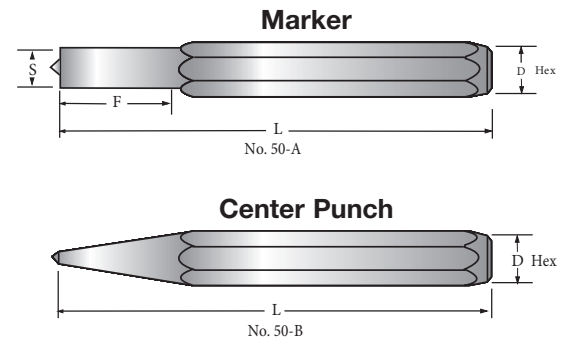
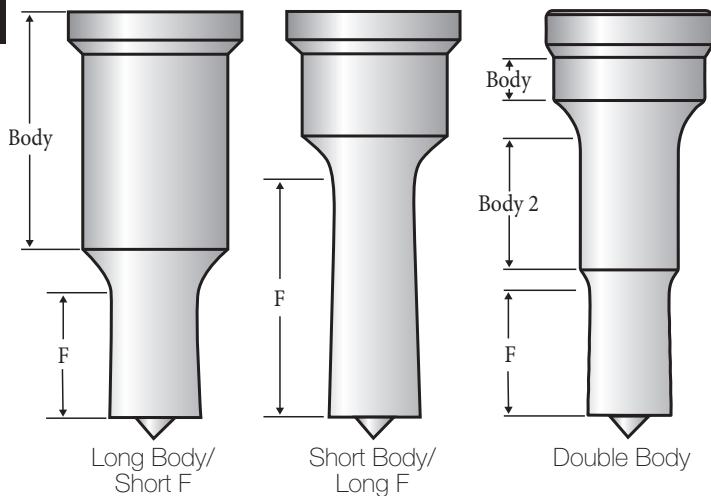

Miscellaneous Tooling

RIPPING PUNCH

An oblong or rectangular ripping punch is used to elongate existing holes or to notch material. The ripping punch is used with a standard oblong or rectangular die. Please specify style number of punch required and advise our sales experts if your machine has an adjustable stroke. Note: The guide (T) is 1/8" longer than the material thickness to allow for material clearance and prevent side loading. Material thickness must not exceed 5/16".

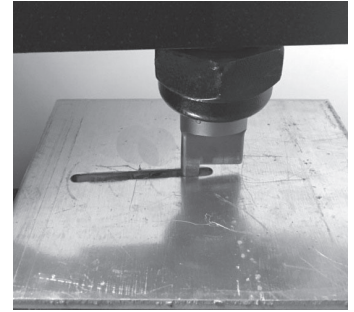
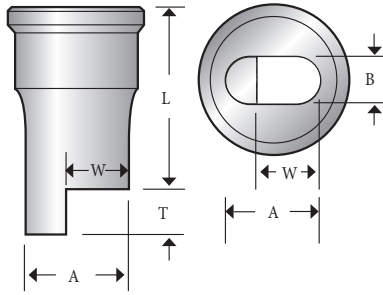

CORNER ROUNDING TOOLING

The corner rounding punch is used to round the corners on **material up to 5/16" thick**. The bottom die has a built in guide at least 1/8" higher than material thickness. Indicate radius (R) and material thickness (T) when ordering.

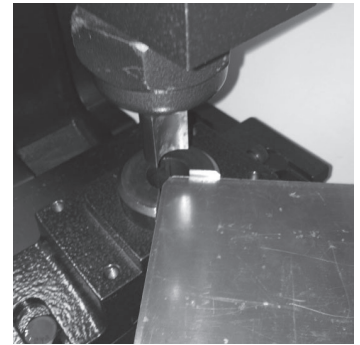
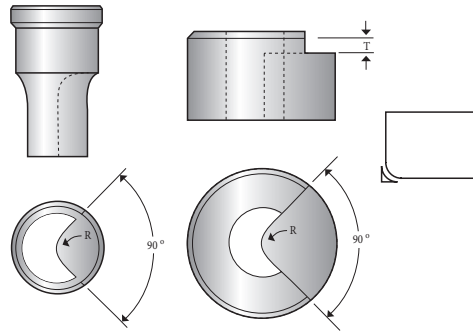

LATTICE BAR (TRIM AND PART) TOOLING

The lattice bar punch allows operator to simultaneously trim and radius strip **material up to 5/16" thick**. The punch or die has a guide that is a minimum of 1/8" longer than the material thickness. When ordering, please specify material thickness and material width. Trim and part (lattice bar) tooling can also include punches for bolt holes.

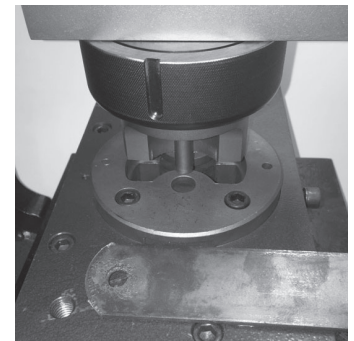
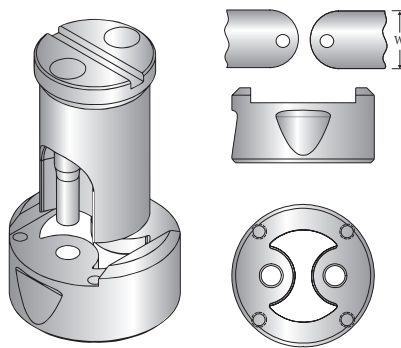

PICKET TOOLING

The picket punch is used to make pickets in ornamental iron. Sizes available up to 1" for thin gauge, hollow wall, square tubing only. 14 gauge (.078) maximum thickness.

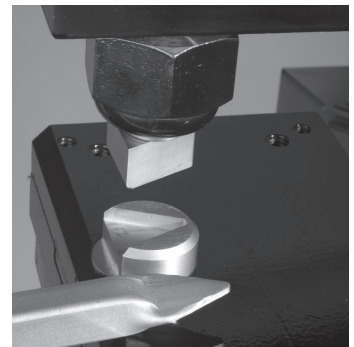
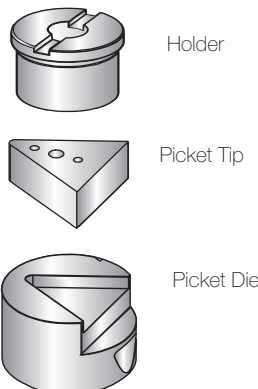

Miscellaneous Tooling

STANDARD COUPLING NUTS

The critical dimensions required to identify a coupling nut are the thread diameter, threads per inch, bore and size of hex from flat to flat. We can manufacture replacements for most machine models.

Coupling nuts are designed to be turned on the stem by hand and then tightened with a wrench or spanner wrench. Over-torquing may cause damage to the threads. Check periodically to ensure that the nut remains tight and the punch cannot move. Loose nuts are a leading cause of punch breakage.

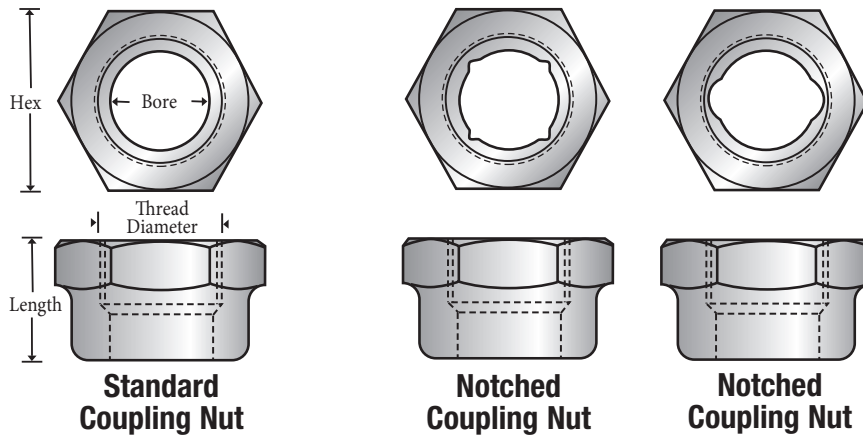

PUNCH STEMS

Shown below are general styles of punch stems. Cleveland Steel Tool can manufacture punch stem replacements for most machine models. Note: The use of two 90° keyways in the face of the threaded end of a punch stem is recommended to ensure proper alignment of shaped punches with matching dies.

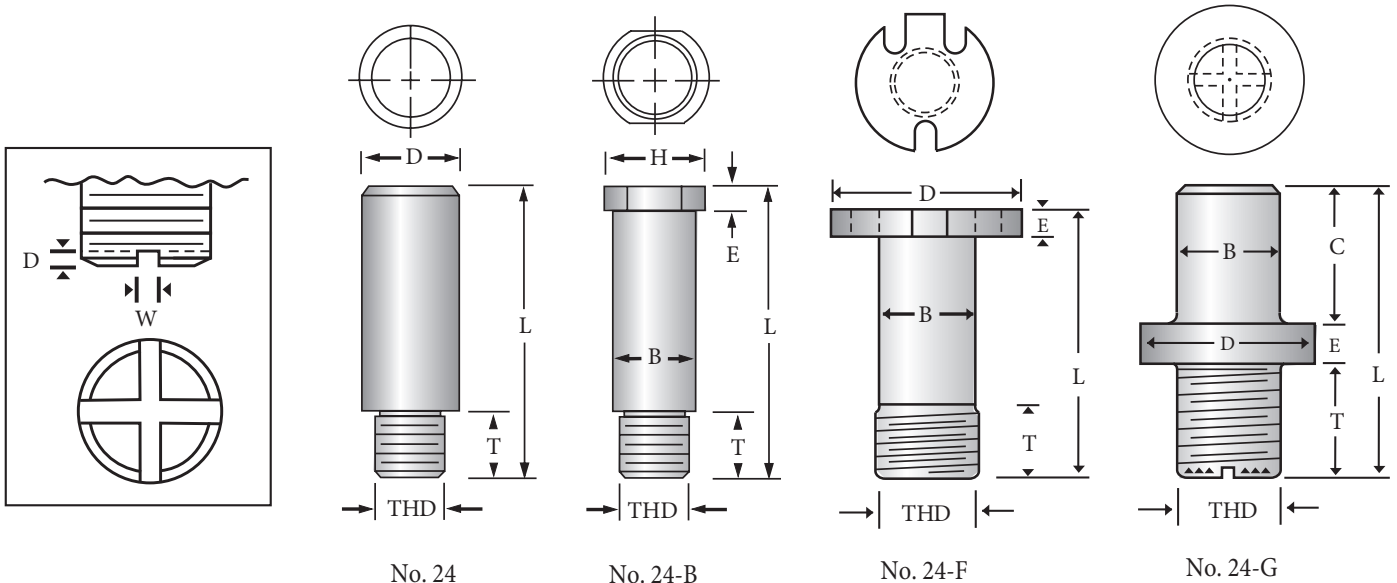



Miscellaneous Tooling

DIE HOLDERS

We can manufacture a replacement or custom die holder for most machines. Some common styles include pedestal and block type holders as shown below. Call our sales staff for more information.

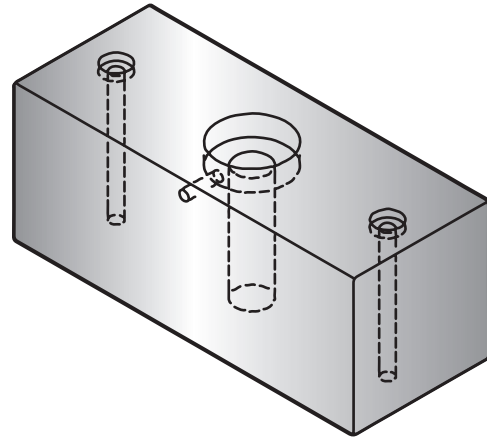
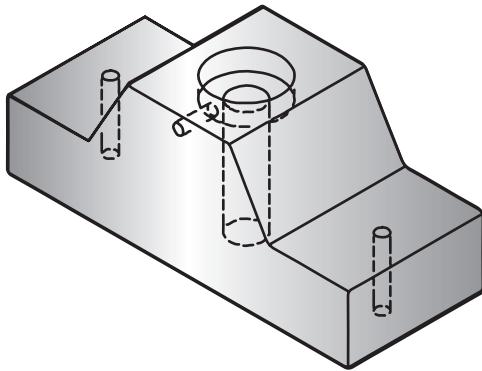

TOOLING TO ADAPT MACHINES

In some instances, it may be desirable to substitute the style of tooling used in your equipment. Filler Blocks or Reducing Sleeves may be used to convert your punch setup, or a Die Liner and Reducing Socket can allow substitution of a different style Die.

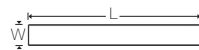

FILLER BLOCK



PUNCH

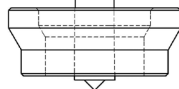

REDUCING SLEEVE

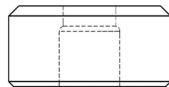

DIE

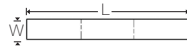

DIE LINER

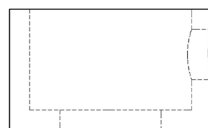

REDUCING SOCKET

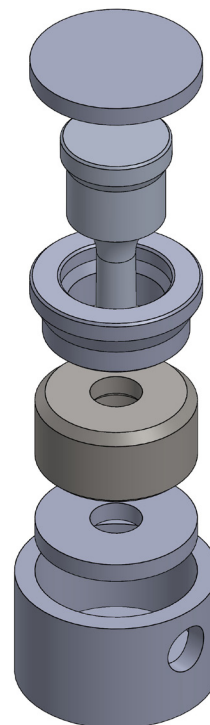

Metal Culvert Tooling

PUNCHES

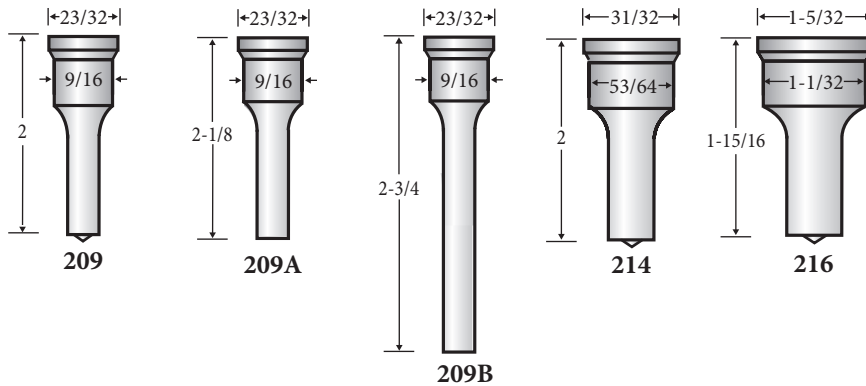

DIES

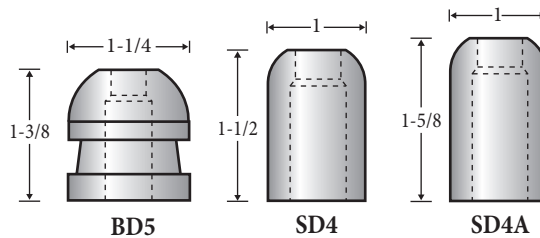

UPPER RIVET

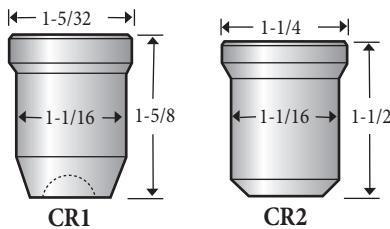

LOWER RIVET

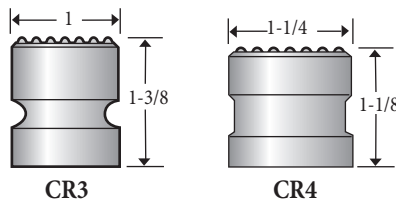

FILLER BLOCKS

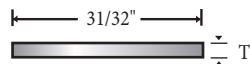

Available in thicknesses of $1/32$, $1/16$, $1/8$ and $1/4$ "

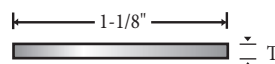

Available in thicknesses of $1/32$, $1/16$, $1/8$, $1/4$ and $5/16$ "

Taper Shank/Leaf Spring Tooling

TAPER SHANK PUNCHES

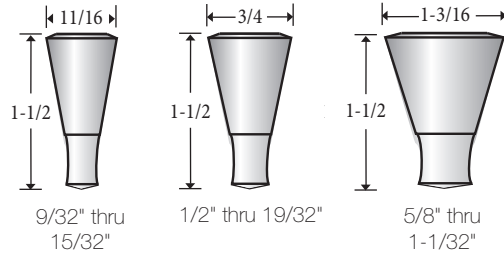

Specify if your application is for hot or cold punching

DIES

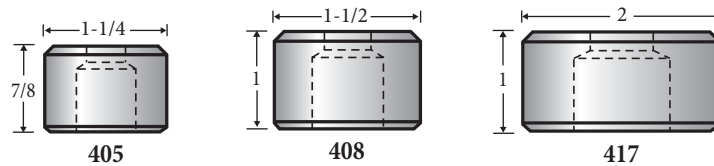

REDUCING SLEEVE

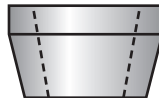

Reducing sleeves allow you to use a punch with a smaller head without changing your coupling nut.

Sleeve22 takes 11/16" head punch.
Sleeve26 takes 3/4" head punch.

COUPLING NUTS

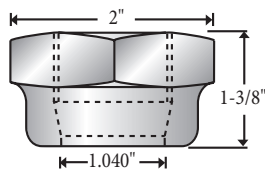

No. 15
Taper Bore
Thread: 1-13/32" -10

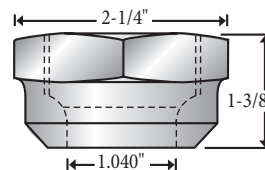

No. 55
Taper Bore
Thread: 1-9/16" -12

Cleveland Steel Tool™ Ironworkers

Model	Punch	Die
All Models	219	413

Note: Cleveland Steel Tool™ Ironworkers use Punch Style 228 or 241 or die Style 419 or 28XX for Oversize Hole Punching.

PUNCHES

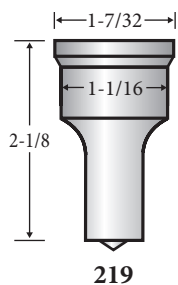

219

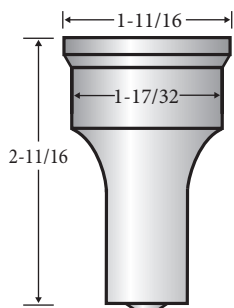

228

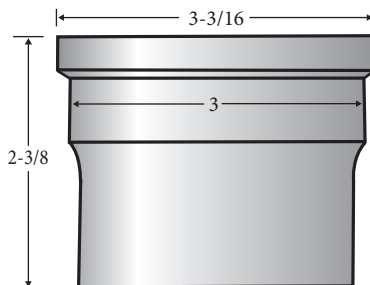

241

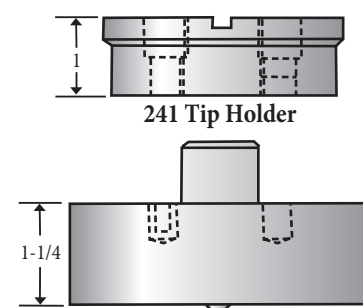

241 Tip Holder

241 Punch Tip
Available up to 4-1/2"

DIES

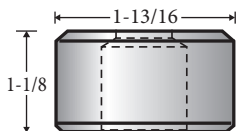

413

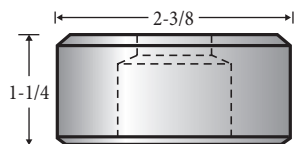

419

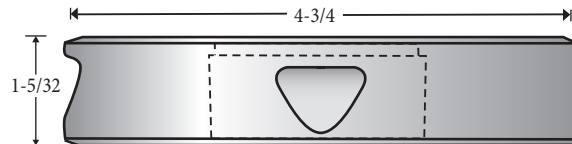

28XX

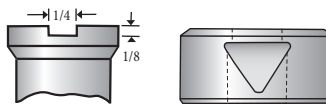

Cleveland Steel Tool Ironworkers use 1/4" x 1/8" Keyways and Whistle Spots for alignment of shaped punches and dies.



Cleveland Steel Tool™ Ironworkers

FLAT BAR SHEAR BLADES

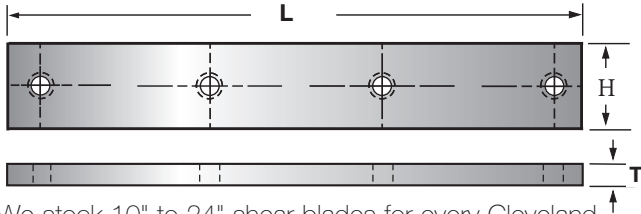

We stock 10" to 24" shear blades for every Cleveland Steel Tool Ironworker. Each blade is reversible with 4 cutting edges. 2 blades required per set.

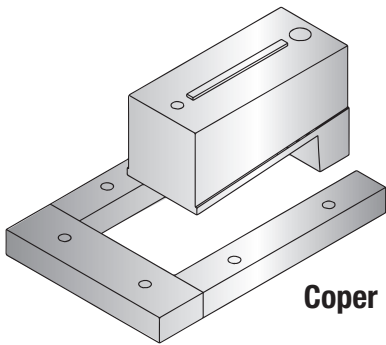

Coper Notcher Blades

ANGLE SHEAR BLADES

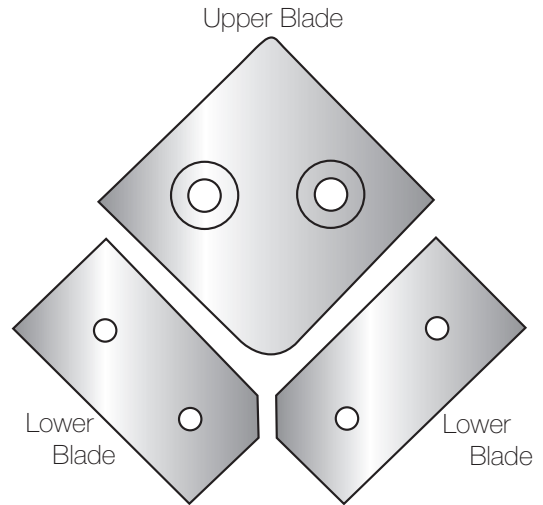

Upper blade is reversible with 2 cutting edges and 2 radii for large and small angles.

PUNCH STEMS AND COUPLING NUTS

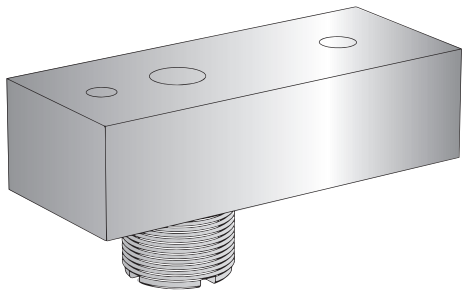

Punch Stem

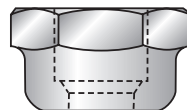
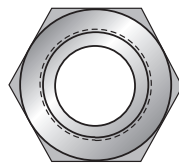

Coupling Nut

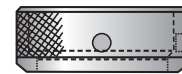
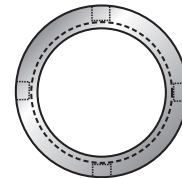

Spanner Nut

241 OVERSIZE ATTACHMENT

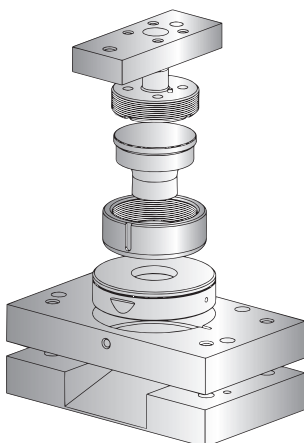

PEDESTAL DIE HOLDER

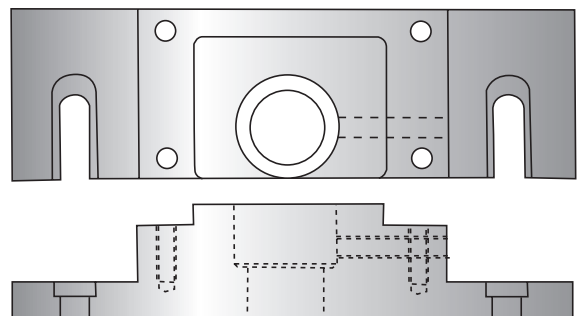

Also available with gauge table.

Cleveland Steel Tool™

Buffalo™ Ironworkers

Model	Punch	Die
0	P36	D85
1/2	P66	D14
1-1/2	P66	D66
2-1/2 pre 1952	P90	D90
2-1/2 after 1952	P3T	D90

PUNCHES

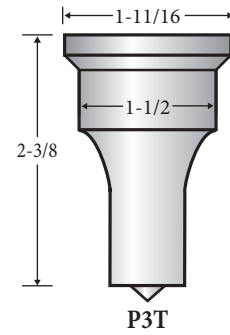
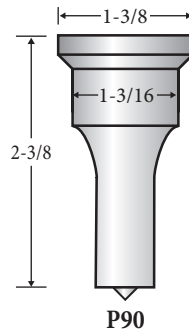
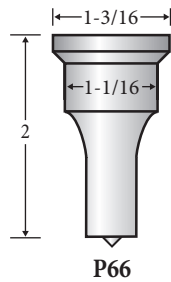
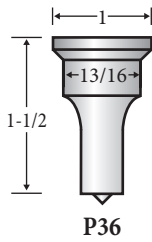

DIES

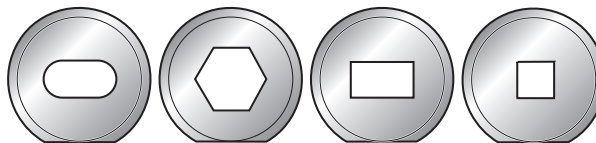
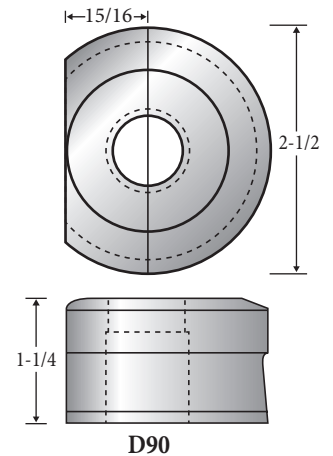
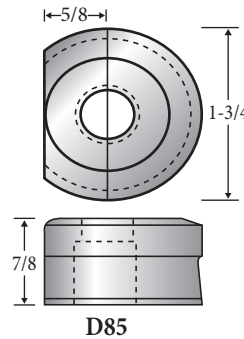
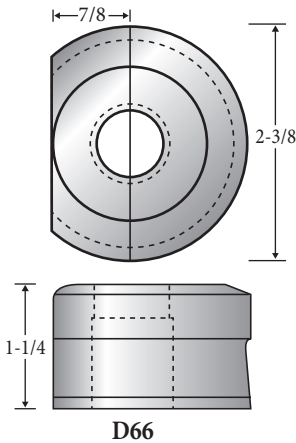
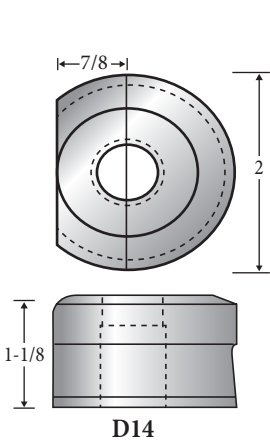

Standard shaped hole die positions shown in relation to the flat. The long dimension of the oblong hole will be furnished parallel to the flat unless otherwise specified.



Buffalo™ Ironworkers

SHEAR BLADES

Model	Notcher Punch	Notcher Die	Coper Punch	Coper Die	Plain Shear Blade	Serrated Shear Blade	Tapered Shear Blade	Barcutter Blades				
								A	B	C	D	E
1/2 pre 1963	1-2NP1	1-2ND0	1-2CP3	(2) 1-2CDB (1) 1-2CD1	1SB3	1SB1	1SB8	1K5A	1K5B	1K5C	1K1D	1K1E
1/2 after 1963	1-2NP1	1-2ND0	1-2CP4	(3) 1-2CD3	1SB3	1SB1	1SB4	1K5A*	1K5B	1K5C	1K5D	not req'd
1-1/2 pre 1963	1-2NP1	1-2ND0	1-2CP3	(2) 1-2CDB (1) 1-2CD1	2SB3	2SBU	2SB9	2K5A	2K5B	2K5C	2K4D	2K4E
1-1/2 after 1963	1-2NP1	1-2ND0	1-2CP4	(3) 1-2CD3 (2) 3CD2	2SB3	2SBU	2SB4	2K5A*	2K5B*	2K5C*	2K9D*	not req'd
2-1/2 pre 1963	3NP0	(3) 3ND1	3CP3	(1) 3CD1 (2) 3CD2	3SB3	3SB9	3SB7	3K9A	3K9B	3K5C	3K9D	3K9E
2-1/2 after 1963	3NP0	(3) 3ND1	3CP4	(3) 3CD1	3SB3	3SB9	3SB7	3K5A	3K5B	3K5C	3K4D	not req'd

Numbers in parenthesis indicate number of pieces required.

*Indicates that these blades are used on machines built 1963-1975. Call the sales department for information on machines built after 1975.

Contact our sales department for accessories for the "0" Buffalo Ironworker

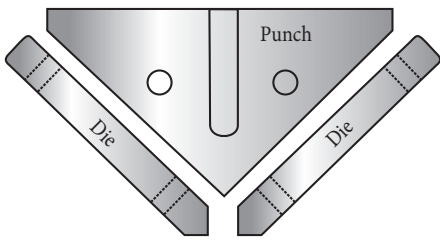

Angle Notcher

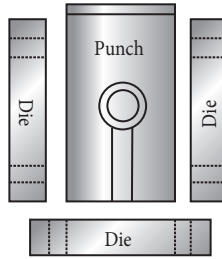

Coper Notcher

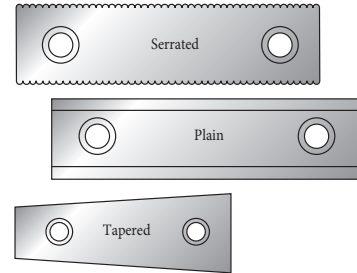

Available Shear Blades

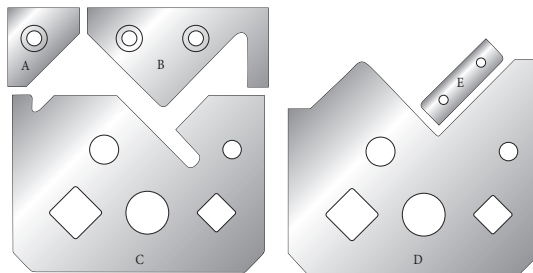

Barcutter Blades

COUPLING NUTS AND PUNCH STEMS

We supply Punch Stems and Coupling Nuts for all Buffalo machines. Contact our sales department or shop our website to find the replacement tools you need.

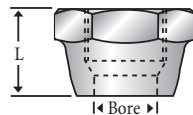

Coupling Nut

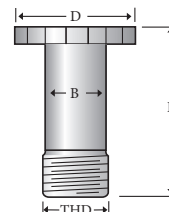
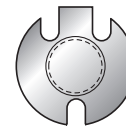
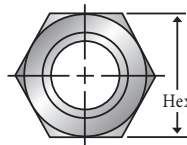

Punch Stem

Clausing™/Metal Muncher™ Ironworkers

Model	Punch	Die
DP50	219	417
DP50/110	228	419
GB35	219	417
GB40	219	417
GB50	219	417
GB70	228	419
GB70-18	228	419
GB100	228	419
GB100-18	228	419
GB135	228	419
GB135-18	228	419
MM35	219	417
MM40	219	417
MM49	219	417
MM61	219	417
MM70	228	419
MM70-18	228	419
MM100	228	419
MM100-18	228	419
MM135	228	419
MM135-18	228	419

Note: Clausing™/Metal Muncher™ Ironworkers use 28XX Punches and Dies for Oversize Hole Punching.

PUNCHES

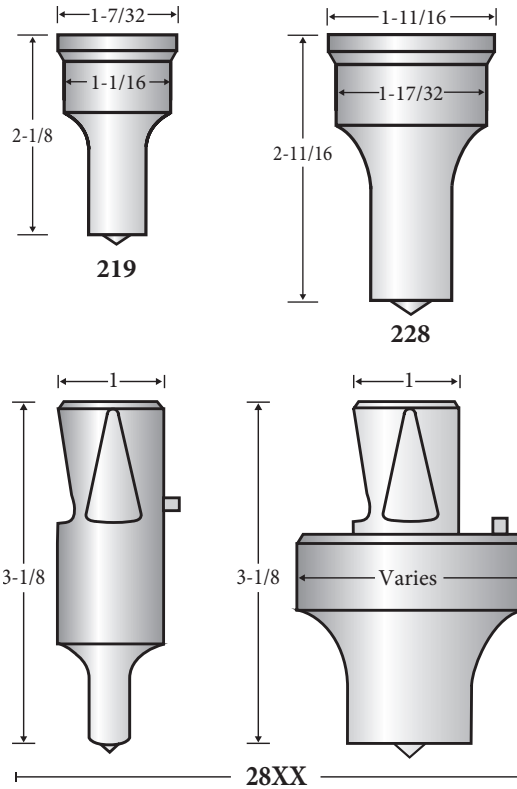

See page 14 for more information on 28XX punches.

DIES

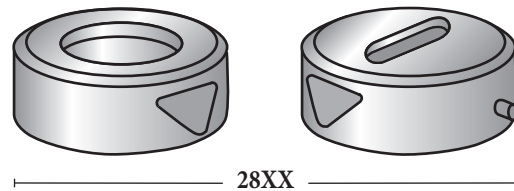
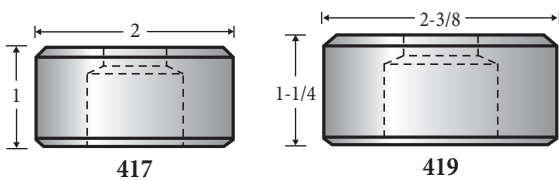

See page 14 for more information on 28XX dies.

SHEAR BLADES

Flat Bar, Angle, Coper or Angle Notcher, Bar Cutter and all other Shear Blades are available.

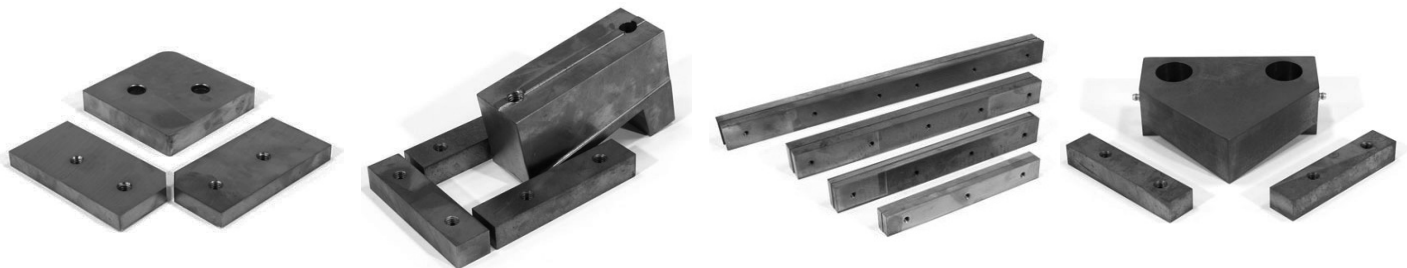



Controlled Automation™ Machines

Model	Punch	Die
2AT-175	64	45
ABL-100 65 Ton	63	47
ABL-100 115 Ton	64	47
ABL-100 143 Ton	228	46
ABL-100-2 65 Ton	63	46
ABL-100-2 115 Ton	64	46
ABL-100-2 143 Ton	228	46
ABL-741	63	47
ABL-74LT	64	47
ABL-86T	63	47
BFC-522	64	47
BFC-530	64	47
PPF-115	64	47

Note: Controlled Automation™ Machines use Punch Style 64, 64XX, or 66 or Die Style 45, 46 or 47XX for Oversize Hole Punching.

PUNCHES

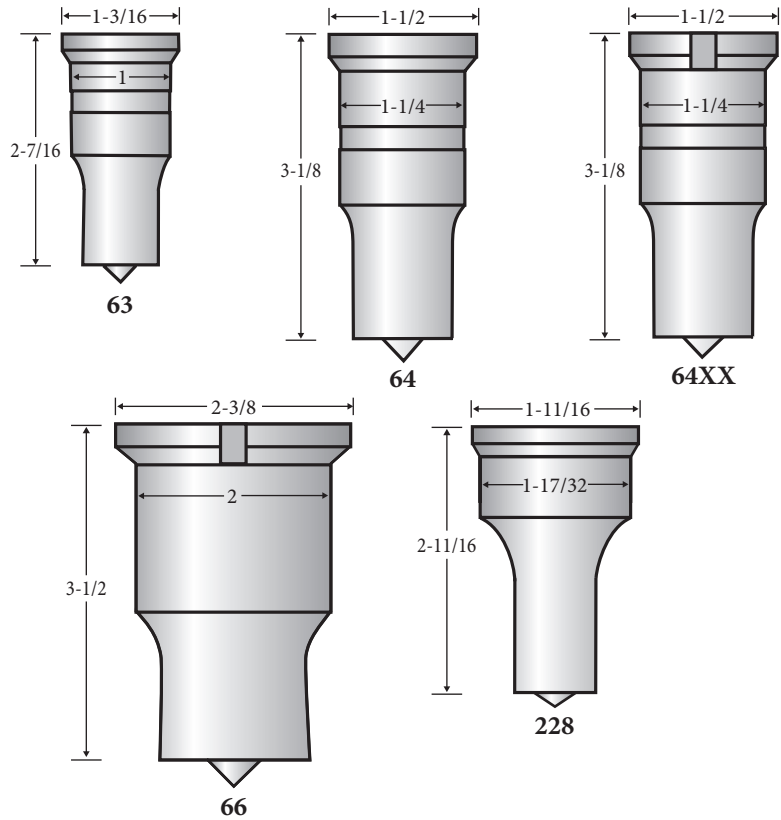

DIES

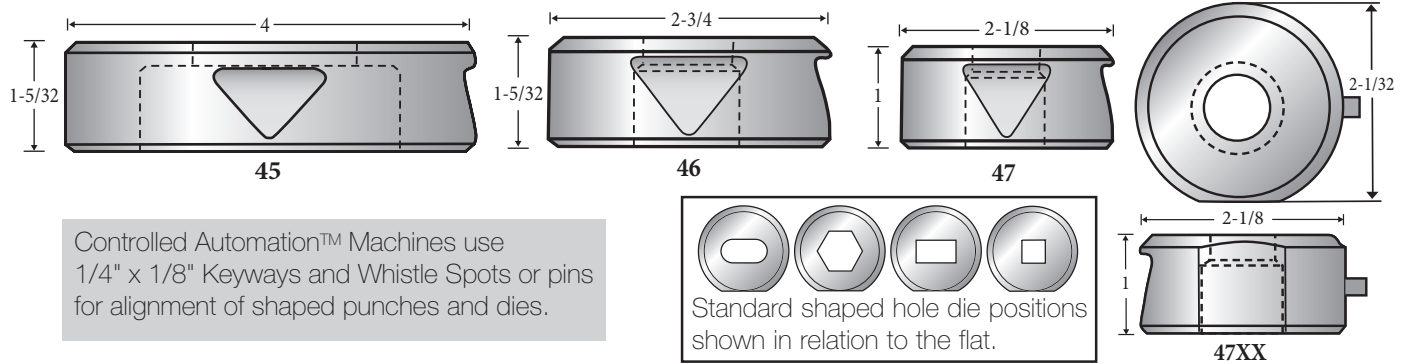

SHEAR BLADES

We manufacture Shear Blades for all types of Ironworkers and can custom manufacture to your specifications.



Controlled Automation™

Edwards™/Hawthorne™/Pittsburgh™/Ironworkers

Model	Punch	Die
All Models	219	413

Note: Edwards™/Hawthorne™/Pittsburgh™ Ironworkers use Punch Style 228 or 241 or die Style 419 or 28XX for Oversize Hole Punching.

PUNCHES

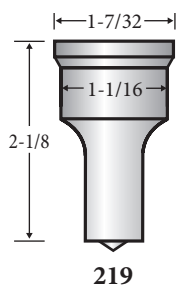

219

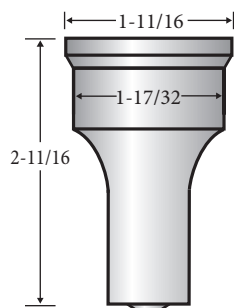

228

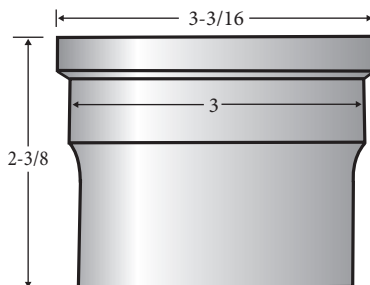

241

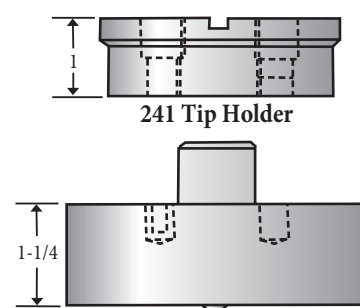

241 Tip Holder

241 Punch Tip
Available up to 4-1/2"

DIES

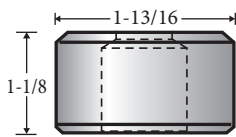

413

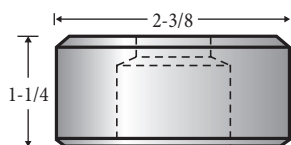

419

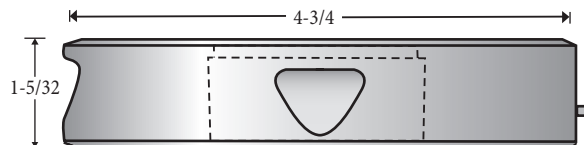

28XX

See page 14 for more information on 28XX dies.

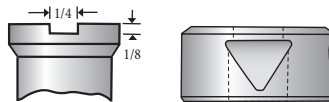

Edwards™/Hawthorne™/Pittsburgh™ Ironworkers use 1/4" x 1/8" Keyways and Whistle Spots for alignment of shaped punches and dies.



Edwards™/Hawthorne™/Pittsburgh™/Ironworkers

FLAT BAR SHEAR BLADES

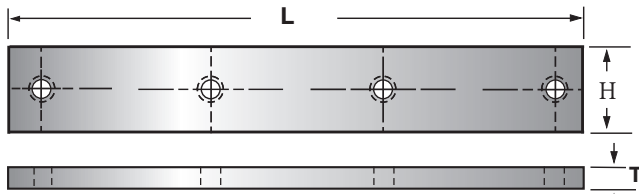

We stock shear blades 10" to 24" for every Edwards™/Hawthorne™/Pittsburgh™/Ironworkers. Each blade is reversible with 4 cutting edges. 2 blades required per set.

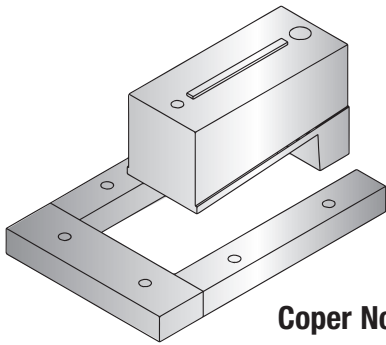

Coper Notcher Blades

ANGLE SHEAR BLADES

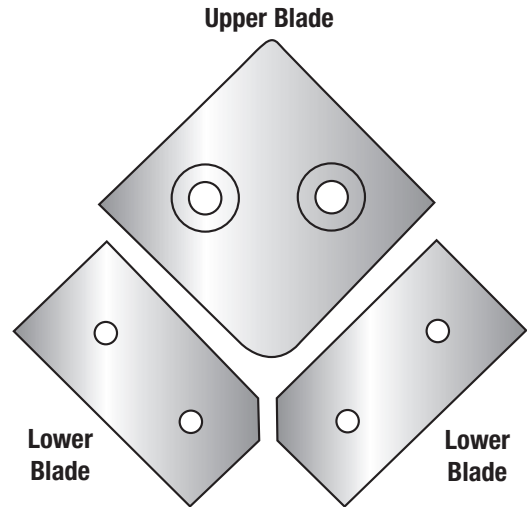

Upper blade is reversible with 2 cutting edges and 2 radii for large and small angles.

PUNCH STEMS AND COUPLING NUTS

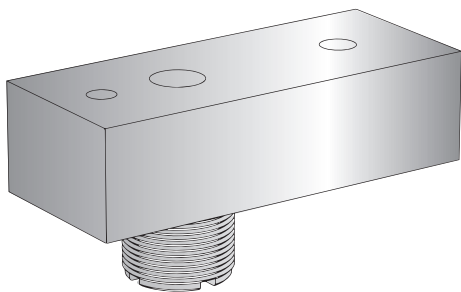

Punch Stem

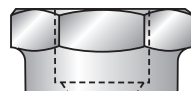
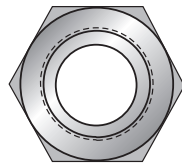

Coupling Nut

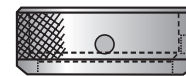
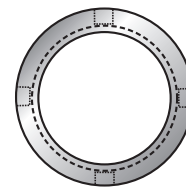

Spanner Nut

OVERSIZE ATTACHMENT

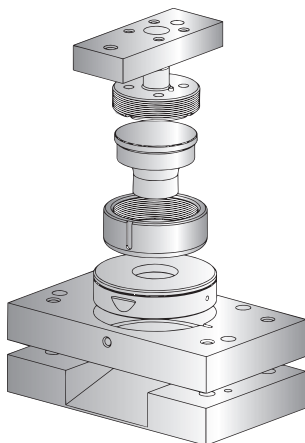

PEDESTAL DIE HOLDER

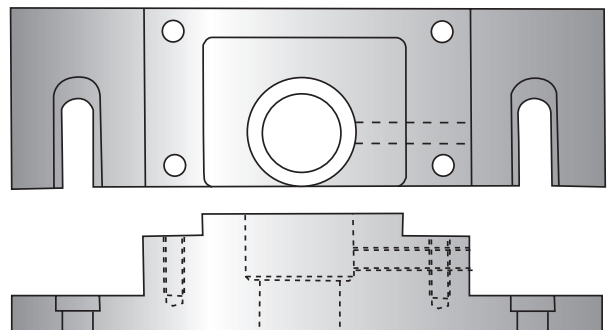

Edwards™/Hawthorne™/Pittsburgh™

Ficep™ Ironworkers

Model	Punch	Die
Angle Line A162	64	417
Super 10	219	408
Super 13	219	417
Super 14	221	417
Super 16-20	228	419

Note: Call our sales department for Ficep™ models not listed.

PUNCHES

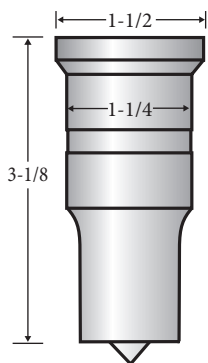

64

Specify with or without centerpoint

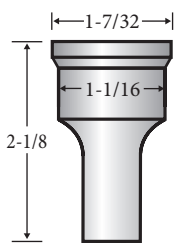

219

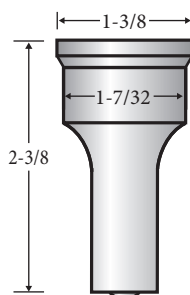

221

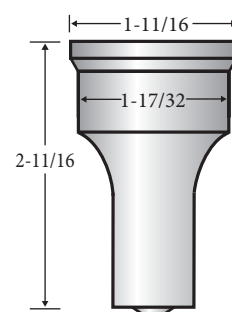

228

DIES

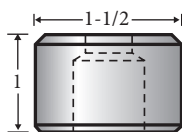

408

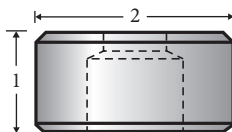

417

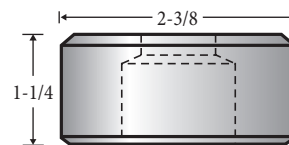

419

Shaped dies have pins in the bottom of the dies.

SHEAR BLADES

Flat Bar, Angle, Coper or Angle Notcher, Bar Cutter and all other Shear Blades are available.

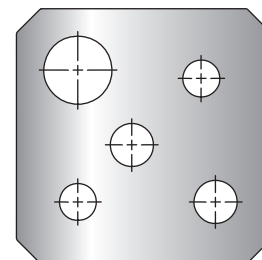
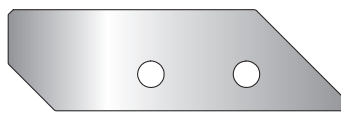
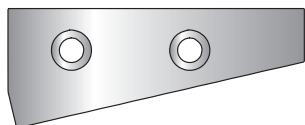



Franklin™ Ironworkers

Model	Punch	Die
AFC5104	64	47
AFC5106	64	47
AFC5108	64	47
AFC5138	64	47
BL100-5	64	47
F530X3	63	48
F550X4	64	47
F570X6	64	47
F5100X6	64	47
F5125X6	66	46
F5175X12	66	46
F5175X6	66	46
F5275X12	66	46
PF196X72G	64	47
SF70A	64	47
W530X4	64	47
W550X7	64	47
W570X8	64	47
W5100X12	64	47
W5100X18	64	47
W5100X30	64	47
W51525X12	66	46
W5175X18	66	46

Note: Franklin™ Machines use Punch Style 66 and Die Style 46 for Oversize Hole Punching.

PUNCHES

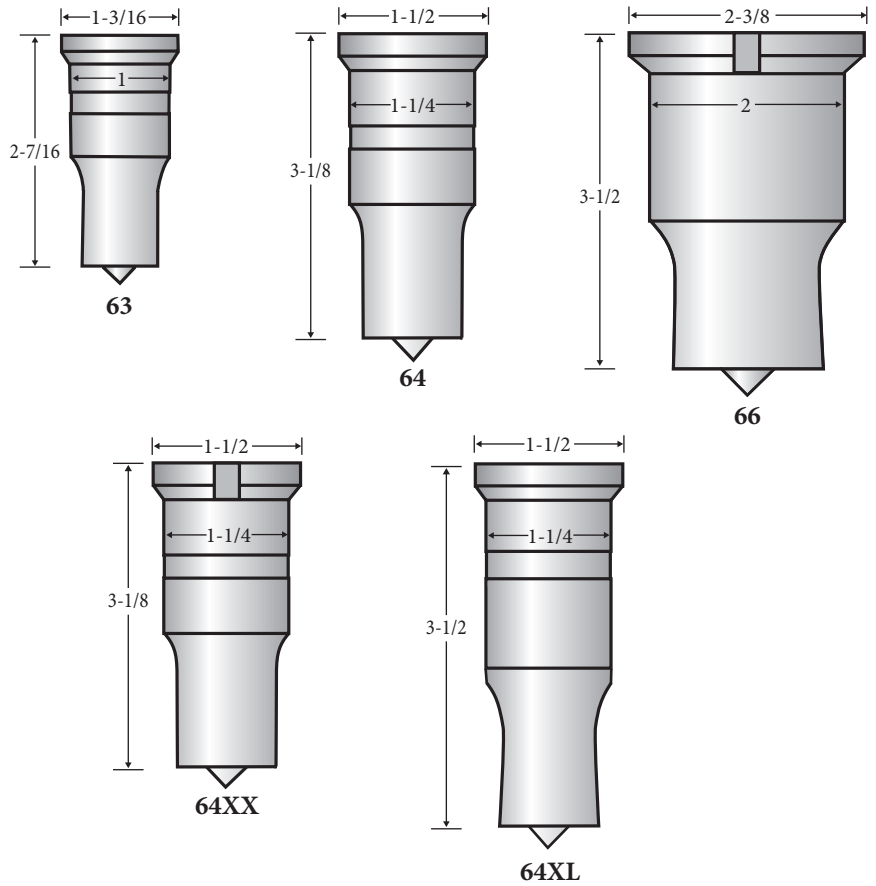

DIES

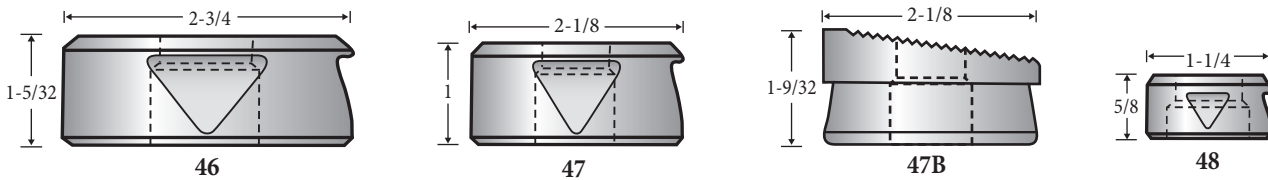

SHEAR BLADES

We manufacture Shear Blades for all types of Ironworkers and can custom manufacture to your specifications.

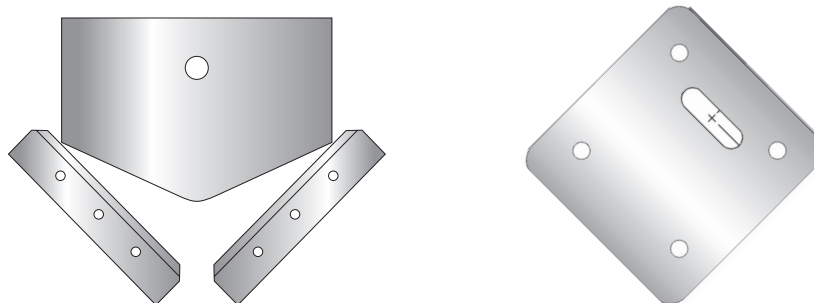

Franklin™

Geka™ Ironworkers

Model	Punch	Die
11 H	219	417
13 H	219	417
16 H	221	417
20 H	221	417
25 H	228	421
55A	221	417
80A	221	417
Bendicrop 50	221	417
Bendicrop 60	221	417
Bendicrop 85	221	417
CEP 11	219	417
CEP 13	219	417
CEP 16	221	417
CEP 20	221	417
H 85 S	221	417
Hydracrop 50	219	417
Hydracrop 55A	221	417
Hydracrop 70	219	417
Hydracrop 100	221	417
Hydracrop 110	221	417
Hydracrop 150	228	421
Hydracrop 165	228	421
Hydracrop 200	228	421
Hydracrop 220	228	421
Maxicrop	219	417
Microcrop	219	417
Minicrop	219	417
Multi 11	208	405
Puma 11	219	417
Puma 13	219	417
Puma 16	221	417
Puma 20	221	417
Puma 50H	219	417
Puma 55H	221	417
Puma 70H	219	417
Puma 80 Dual Static	221	417
Puma 100H	221	417
Puma 110A	221	417
Puma 110H	221	417
Puma 150H	228	421
Puma 165H	228	421
Puma 200H	228	421
Puma 220H	228	421

PUNCHES

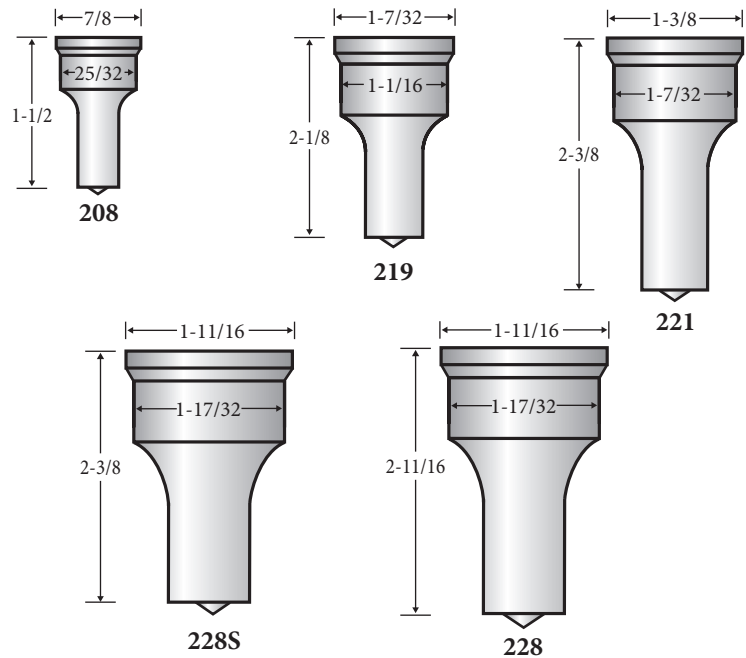

OVERSIZE

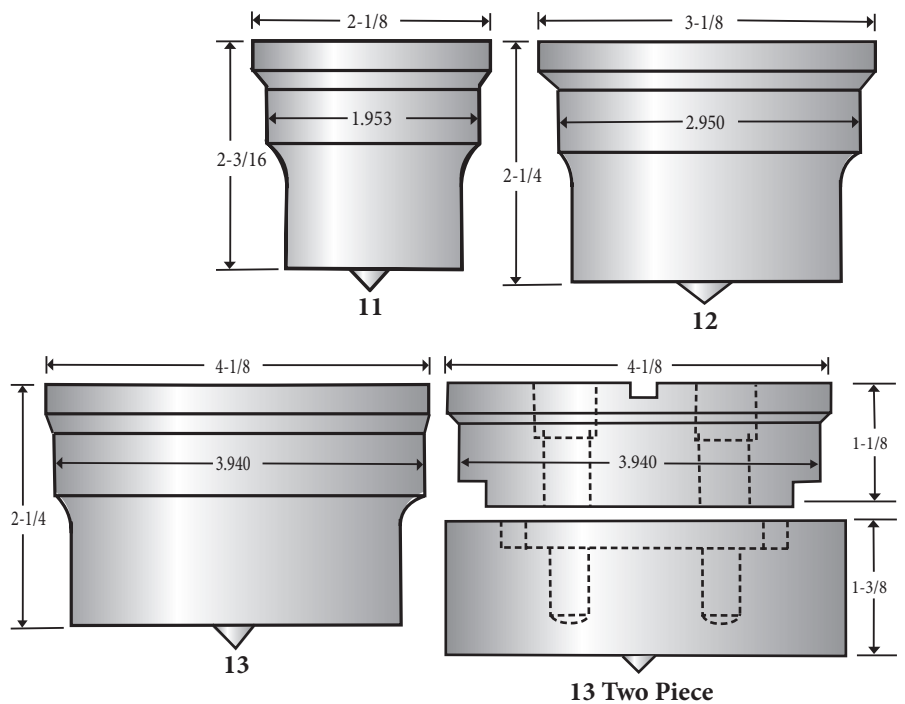

Note: Geka™ Ironworkers use Punch Style 228 or 228 Short, 11, 12, 13, (13 Two Piece) or Die Style 421, 11, 12, 13, 60mm or 200mm for Oversize Hole Punching.

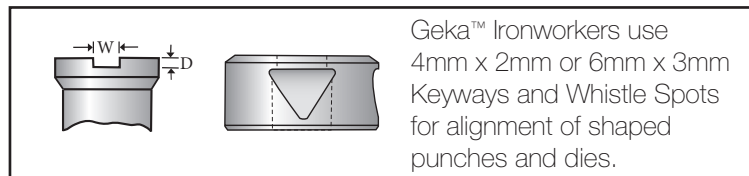



Geka™ Ironworkers

DIES

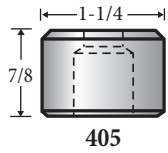

405

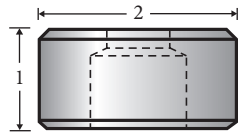

417

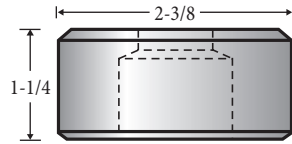

419

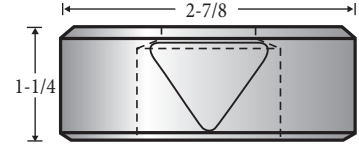

421

OVERSIZE DIES

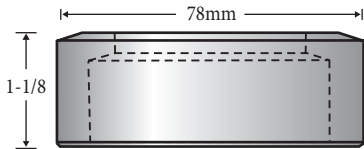

11

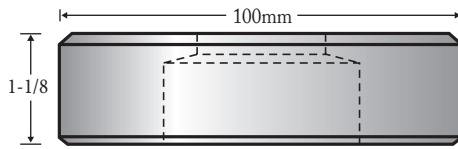

12

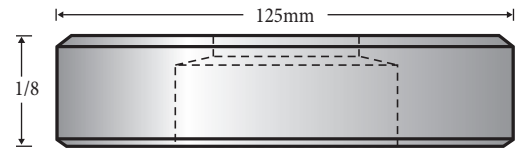

13

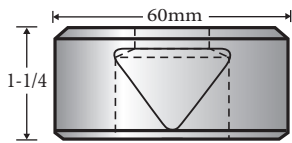

60mm

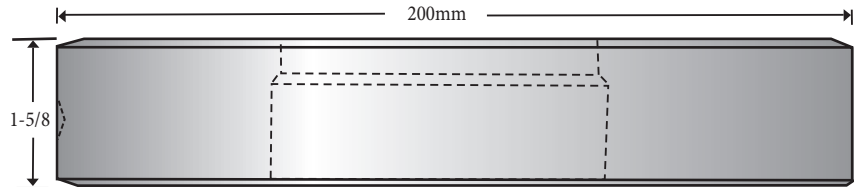

200mm

GEKA OFFSET TOOLING

228 Offset Insert Holder

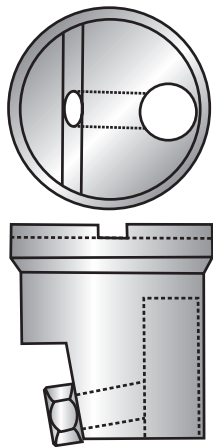

Punch Insert



Die Insert

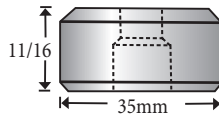

60mm Offset Die Holder

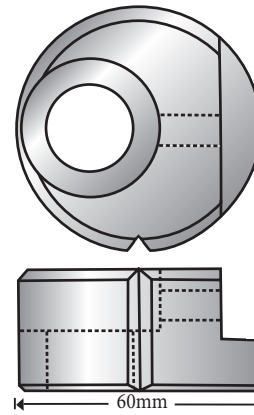

SHEAR BLADES

We manufacture Shear Blades for all types of Ironworkers and can custom manufacture to your specifications.

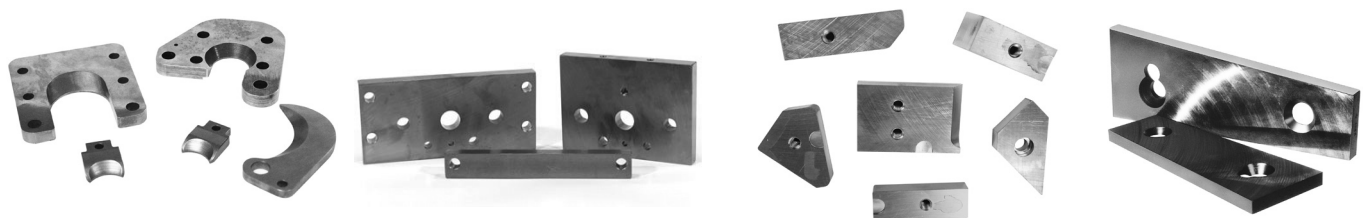

Hendley & Whittemore™ Ironworkers

Model	Punch	Die
51	208	408
52	208	408
53	216	408
54	216	417
55	221	417
55-1/2	228	419

PUNCHES

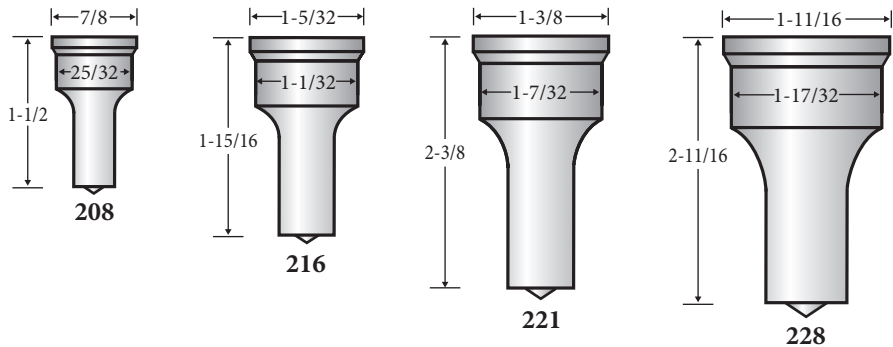

DIES

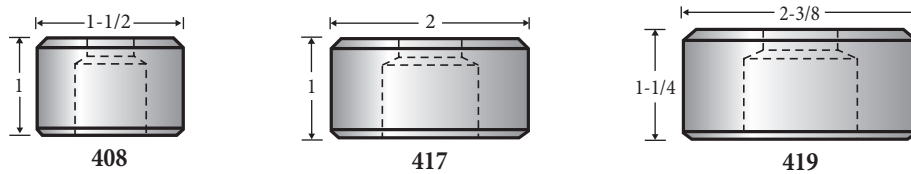

PUNCH STEMS

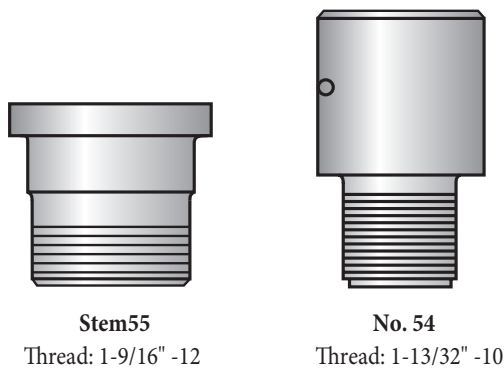

SHEAR BLADES

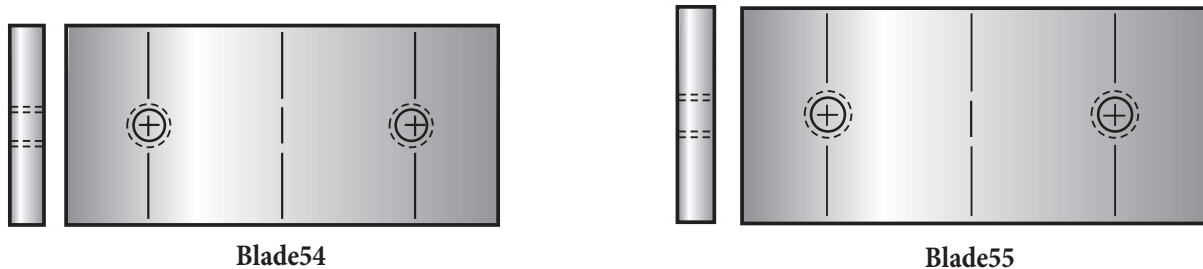

Hendley & Whittemore™



Hill-Acme™ /Kling™ Ironworkers

Model	Punch	Die
#3	216	402
#3 Combination	208	402
#30	216	402
#3A	221	402
#4	221	402
#4 Combination	221	402
#4A	221	402
#5	221	402
#50	221	402
#6	221	402
#6A	221	402
#7	228	408
#7 Combination	228	408
#7A	228	408
MW30	216	402
MW50	221	402

Note: Hill-Acme™/Kling™ Ironworkers use Die Style 408, 417, or 419 for Oversize Hole Punching.

PUNCHES

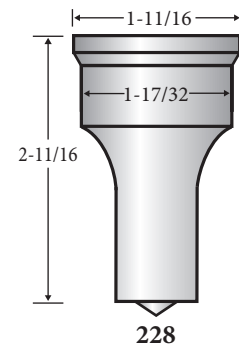
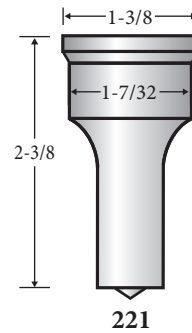
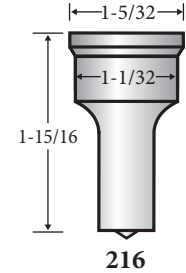
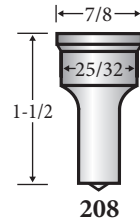

DIES

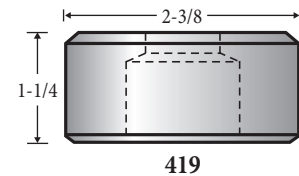
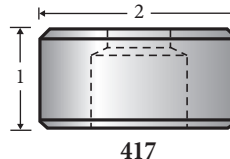
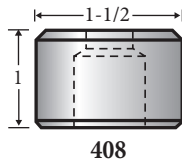
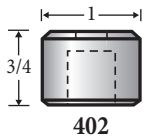

SHEAR BLADES

We manufacture Shear Blades for all types of Ironworkers and can custom manufacture to your specifications.



Hill-Acme™ /Kling™

HMI™ (Hydraulic Machines, Inc.™) Ironworkers

Model	Punch	Die
35-19	219	417
35-20	219	417
35DT-19	219	417
35DT-20	219	417
42-20	221	417
50-19	228	419
50-20	228	419
50-25	228	419
50-31	228	419
50DT-19	228	419
50DT-20	228	419
58-20	228	419
70-31	228	419
90-25	228	419
90-31	228	419

Note: HMI™ (Hydraulic Machines, Inc.™) Ironworkers use 28XX Punches and Dies for Oversize Hole Punching.

PUNCHES

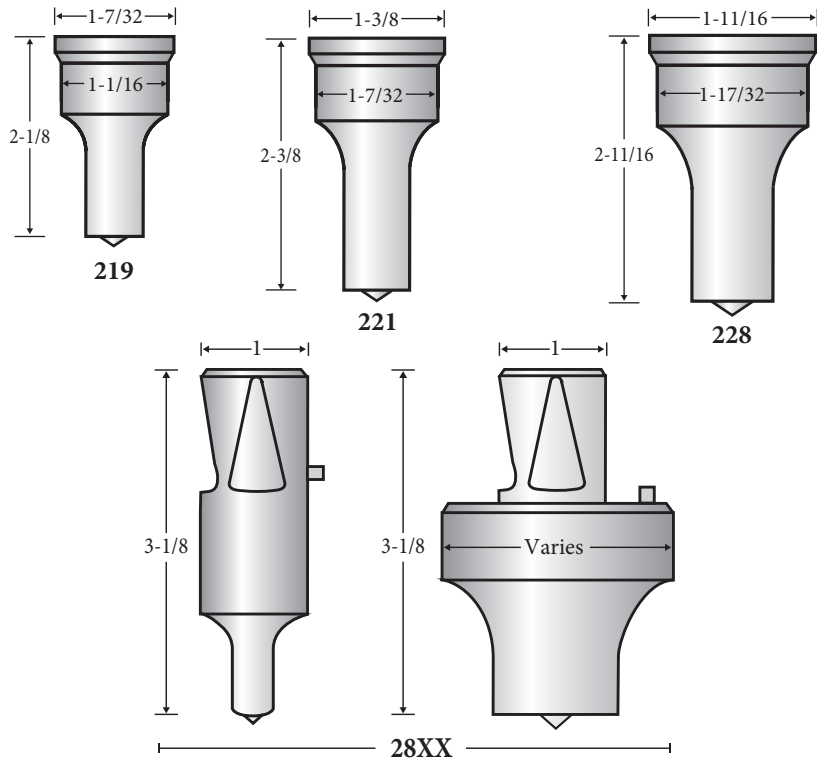

See page 14 for more information on 28XX punches.

DIES

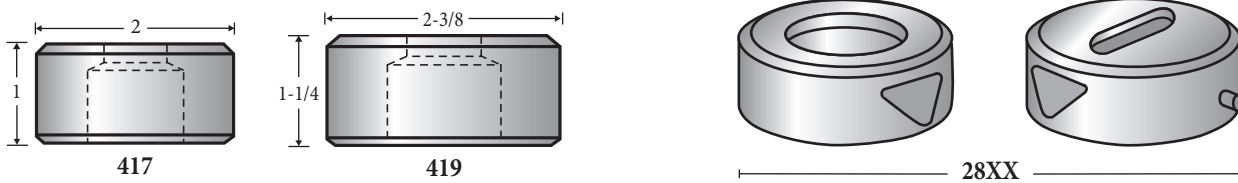

See page 14 for more information on 28XX dies.

SHEAR BLADES

Flat Bar, Angle, Coper or Angle Notcher, Bar Cutter and all other Shear Blades are available.





Hougen-Ogura™ Machines

PUNCHES AND DIES

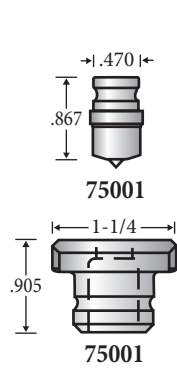

Max Punch Size: 7/16
Max Material Thickness: 1/4

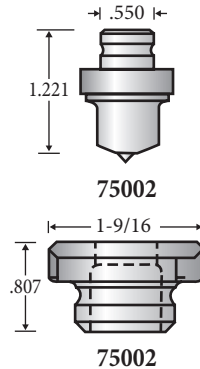

Max Punch Size: 11/16
Max Material Thickness: 1/4

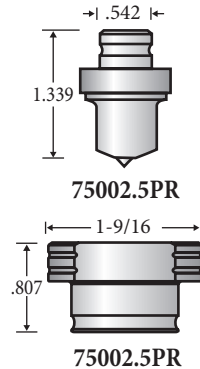

Max Punch Size: 3/4
Max Material Thickness: 1/4

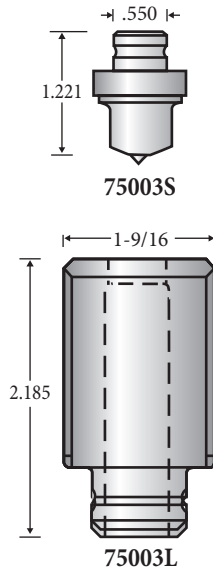

Max Punch Size: 25/32
Max Material Thickness: 1/4

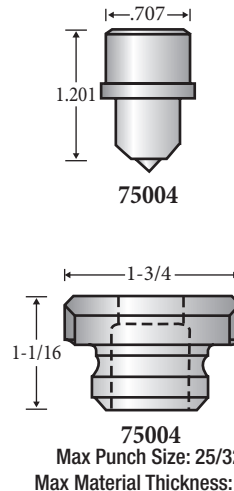
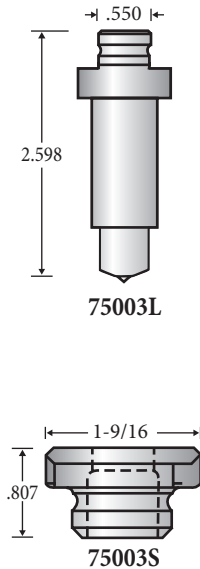

Max Punch Size: 25/32
Max Material Thickness: 3/8

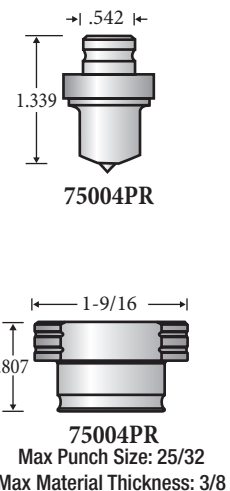

Max Punch Size: 25/32
Max Material Thickness: 3/8

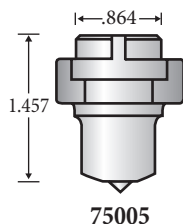

Max Punch Size: 7/8"
Max Material Thickness: 3/8"

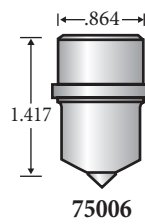

Max Punch Size: 15/16"
Max Material Thickness: 1/2"

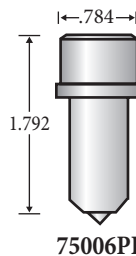

Max Punch Size: 15/16"
Max Material Thickness: 1/2"

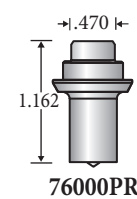

Max Punch Size: 19/32"
Max Material Thickness: 1/4"

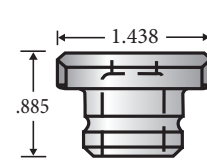
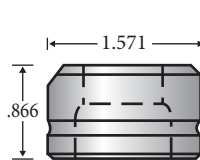
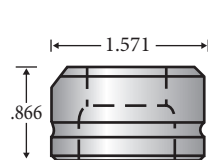
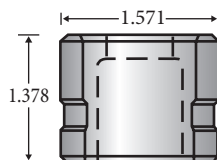

Hougen-Ogura™

Mubea™ Ironworkers

Mubea™

Model	Punch	Die
0	H1	H1
48-4	H1	H1
50-4	H1	H1
71-5	H1	H1
88-6	H1	H1
110-7	H2	H2
143	H2	H2
143-8	H2	H2
350	BF10	H1
350E	H1	H1
450	H1	H1
500	H1	H1
550	H1	H1
560	H1	H1
600	H1	H1
700	H1	H1
750	H1	H1
800	H1	H1
900	H2	H2
900	H2	H2
1100	H2	H2
1300	H2	H2
BF10	BF10	H1
BFL 350	H1	H1
BFLH 400	H1	H1
Bulldog 65	H1	H2
HIW 450	H1	H1
HIW 1000	H2	H2
HIW 1000	H2	H2
HP 450	H1	H1
HPS 250	H1	H1
HPSN 350	H1	H1
KBL 0	H1	H1
KBL 1/2	H1	H1
KBL 1-1/2	H1	H1
KBL 3-1/2	H2	H2
KBLH 500	H1	H1
KBLH 1000	H2	H2
KL 33	H1	H1
KL 110	H2	H2
KLH 500	H1	H1
KLH 1000	H2	H2
KLS 1100	H2	H2
KLSH 550	H1	H1
KLSH 1000	H2	H2
KLSH 1000	H2	H2
MIW 400	H1	H1
Profi 500	H1	H1
KLSH 550	H1	H1
MIW 400	H1	H1
Profi 500	H1	H1

PUNCHES

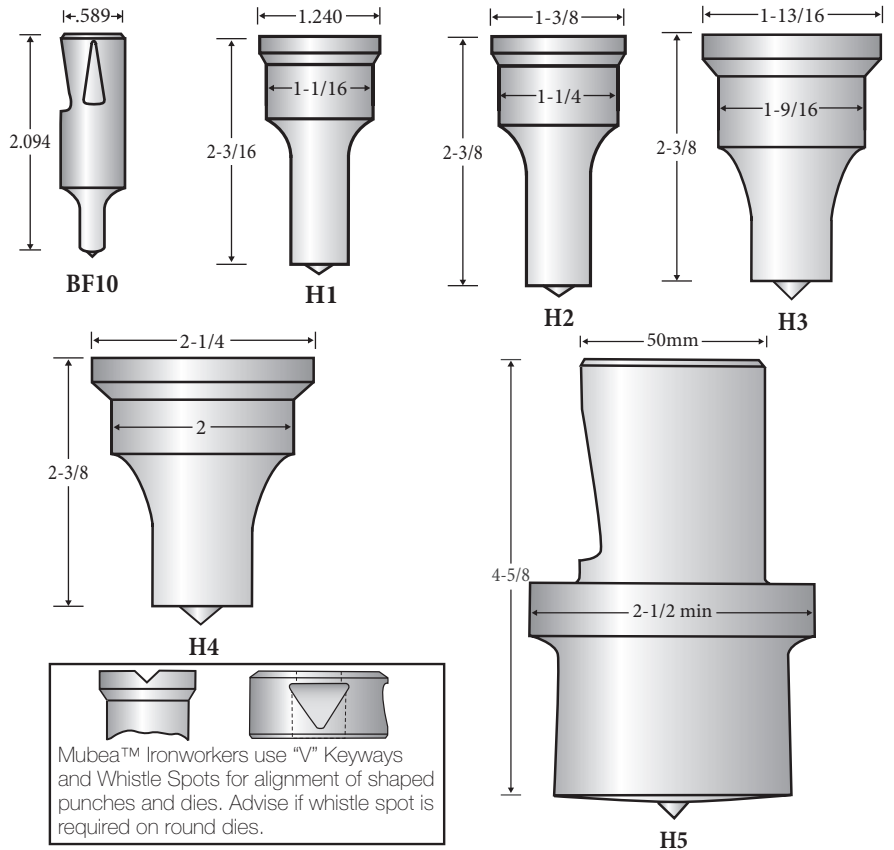

DIES

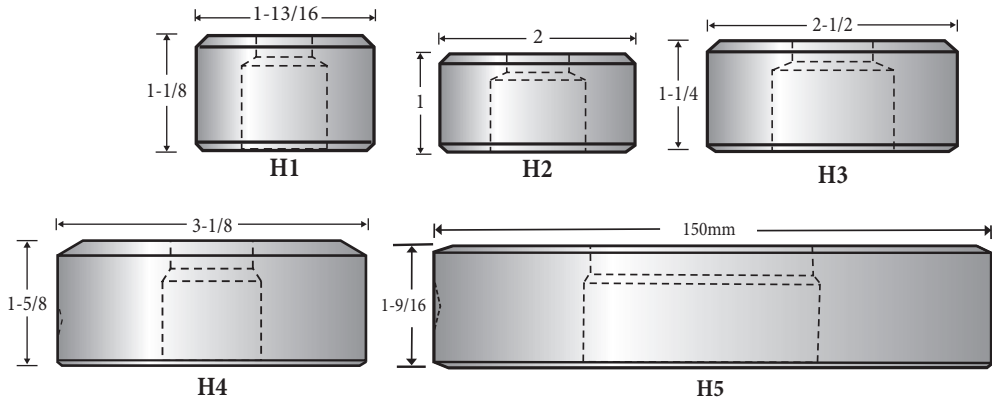

SHEAR BLADES

We manufacture Shear Blades for all types of Ironworkers and can custom manufacture to your specifications.

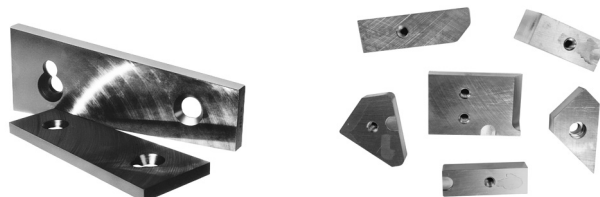

Note: Mubea™ Ironworkers use H3, H4, H5 for Oversize Hole Punching.



Nitto Kohki™ Machines

Model	Punch	Die
All Models	NKP	NKD

Note: Nitto Kohki™ Machines use NKP-O and require a Split Coupling Nut for Oversize Hole Punching.

PUNCHES AND DIES

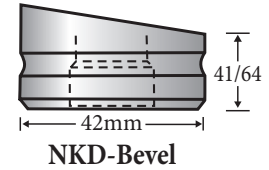
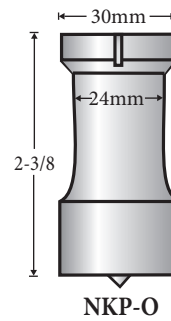
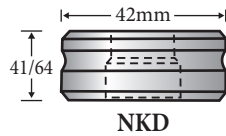
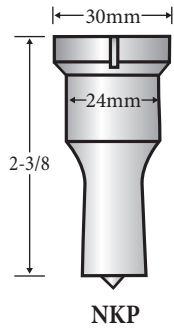

One locating pin is provided in the head of shaped punches.

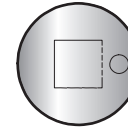
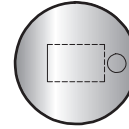
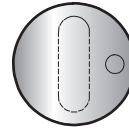
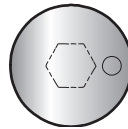
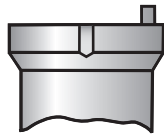

COUPLING NUTS

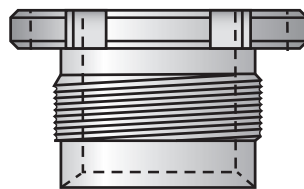
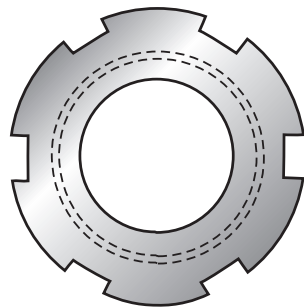

NK Cnut

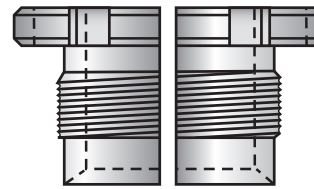
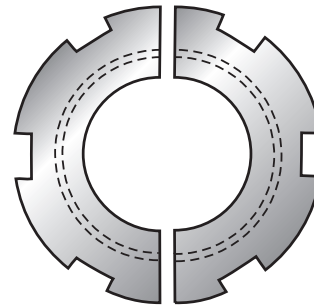

NK Cnut Split

For oversize hole punching

Nitto Kohki™

Peddinghaus™ Machines

Model	Punch	Die
31/44	216	413
44/66H	216	413
66/88	216	413
66/110H	216	413
88/120	216	413
88/140	221	417
110/140	221	417
110/175/H	221	417
120/185	221	417
210/11	216	413
210/13	216	413
210/16	221	417
210/20	221	417
210/25	228	419
225/11	216	413
225/13	216	413
225/16	221	417
225/20	221	417
225/25	228	419
225B100	221	417
225B130	228	419
225B45	216	413
225B60	216	413
225B80	221	417
360H	216	413
400H	216	413
440	216	413
450m	216	413
550	216	413
660	216	413
880	216	413
881	221	417
1050	221	417
2000CNC	64	47
7130 Duplicator	64	47
Anglemaster	64Y	47/45
AFCPS-833	64	47
Anglemaster	64Y	47/45
Anglemaster 623	64	47
Anglemaster 643	64	47
Anglemaster 645	64	47
Anglemaster 823	64	47
Anglemaster 823B	65	291
Anglemaster 1563	64	47
Anglemaster 2063	64	47
Beam Fabricator	65	47F
BPL1000/5	64	47
Bradley 500	221	417
Bradley 700	221	417
Bradley 1100	221	417
Fabripunch 118	64	47

PUNCHES

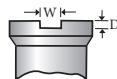
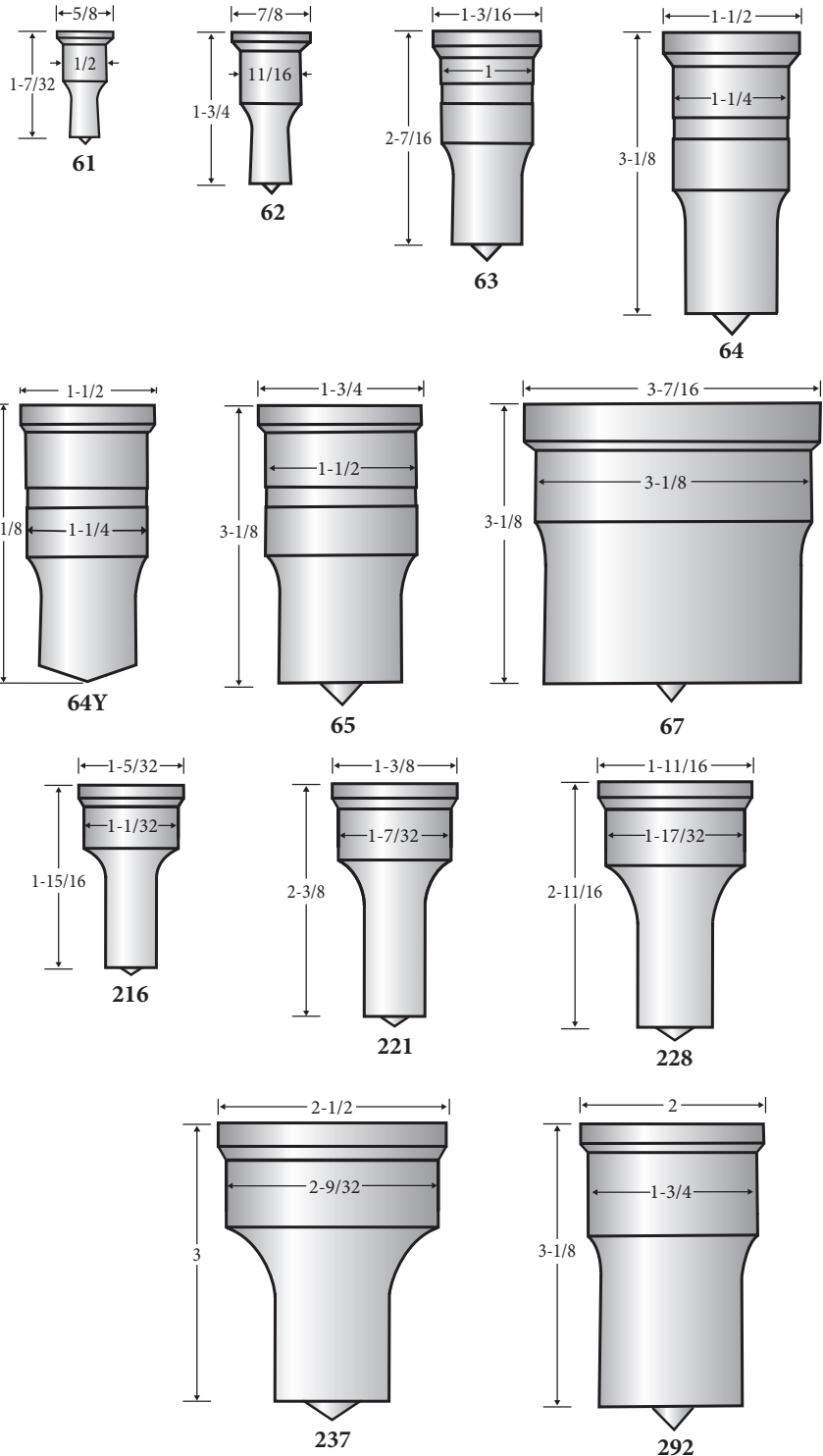

Keyways and whistle spots are recommended for alignment of shaped punches and dies. When ordering, specify the width and depth of the keyway required.



Peddinghaus™ Machines

Model	Punch	Die
Fabripunch 120	64	47
Fabripunch 500/3	64	47
Fabripunch 600/3	64	47
Fabripunch 1120	64	47
Fabripunch 1154	64	47
Fabripunch 1154-30	64	47
Fabripunch 1170	64	47
Fabripunch 1500/3	64	47
Fabripunch 1800/3	64	47
Forax 25E	216	413
Forax 45	216	413
Forax 65	216	413
Forax 80	221	417
Forax 100	221	417
G1100	221	417
H40	216	413
H60N	216	413
H100	221	417
H1000	221	417
H1000GA	221	417
H1100	221	417
H1400	228	419
H1400	228	419
Ocean Clipper	64	47
Portable FP6	61	49
Portable FP12	62	48
Portable FP20	62	48
Portable FP20-4	62	48
Portable FP20-6	62	48
Portable FP35	63	47
Portable FP35-8	63	47
Portable FP35CC	63	48
Portable FP45	64	47
Portable FP60	64	47
Portable FP80	64	47
Portable FP80-9	64	47
Portable FP100	64	47
Portable FP100-12	64	47
Portable FP140-12-1/2	67	44
Portable FP140-6-1/4	67	44
Portable FP250-12-1/2	67	43
Portable Stationary	140	292
Portable WP20	62	48
Portable WP35	63	48
Portable WP60	64	47
Portable WP80	64	47
Portable WP100	64	47
Portable WP100-18	64	47
Portable WP100-25	64	47
Portable WP140	292	291

DIES

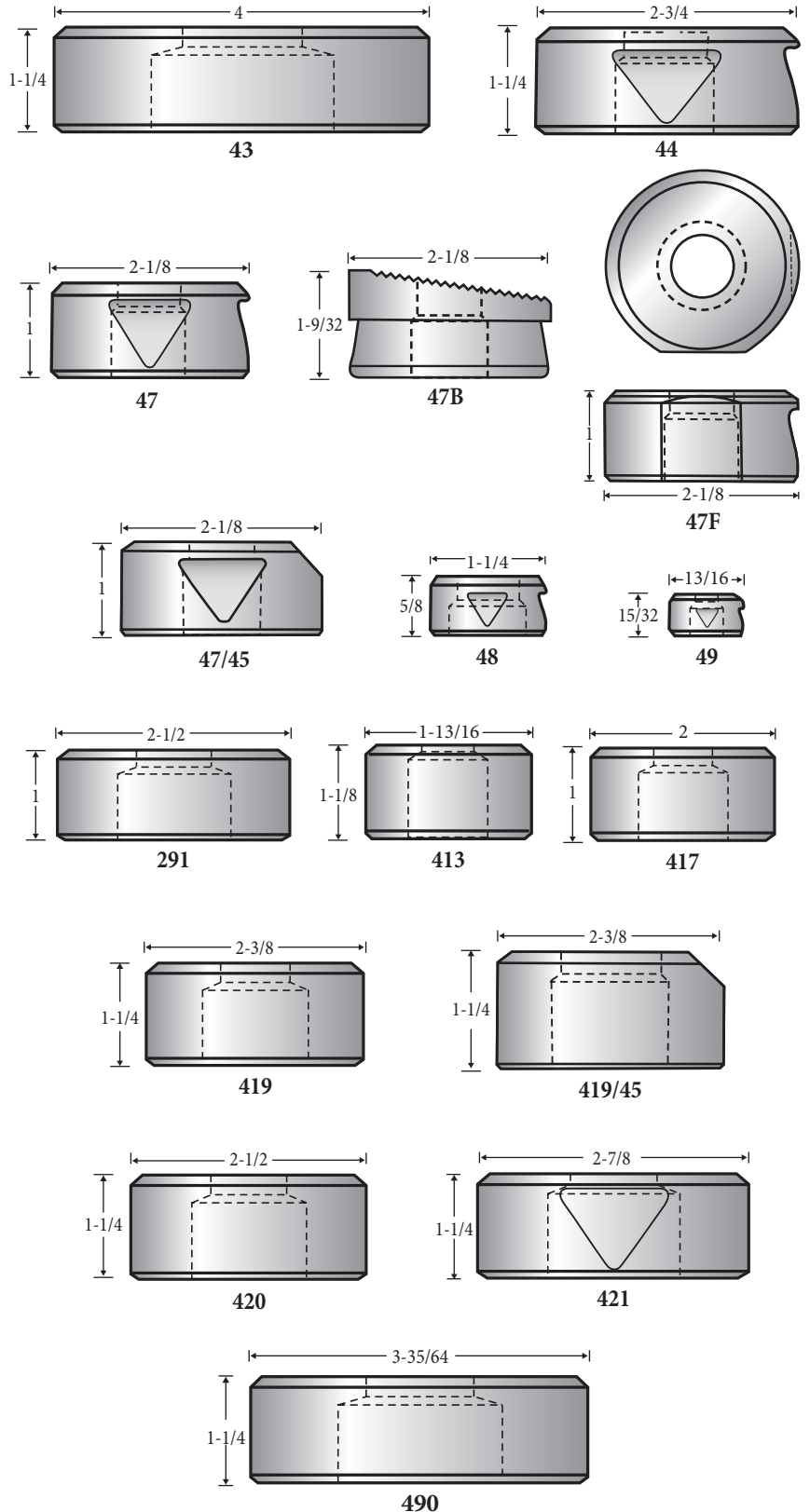

Peddinghaus™

Note: Peddinghaus™ Machines use Punch Style 65, 67, 237 or 292 and Die Style 43, 44, 291, 420, 421 or 490 for Oversize Punching.

Peddinghaus™ Machines

COUPLING NUTS

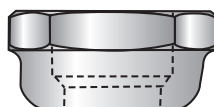

FC-228
Hex Nut

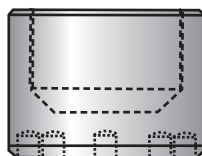
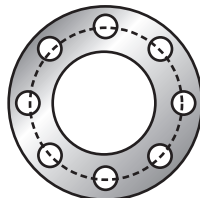

Spanner Nut

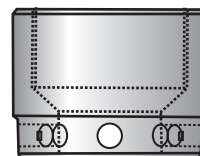
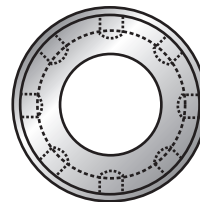

Spanner Nut

Spanner Nut	Thread	Bore	Hex	Punch
FC-61	12, 7/8"	1/2"	1-1/2"	61
FC-62	14, 1"	11/16"	1-3/16"	62
FC-63	12", 1-3/8"	1"	1-15/16"	63
FC-64	12, 1-7/8"	1-1/4"	2-3/4"	64
FC-65	12, 1-7/8"	1-1/2"	2-3/4"	65

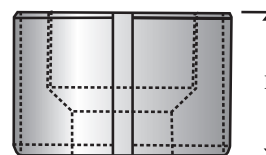
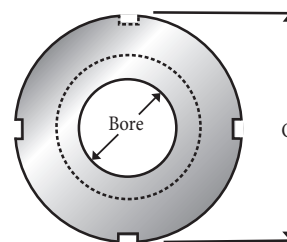

FC-61, FC-62, F-63
FC-64, FC-65

Spanner Nut

SHEAR BLADES

Flat Bar, Angle, Coper or Angle Notcher, Bar Cutter and all other Shear Blades are available.

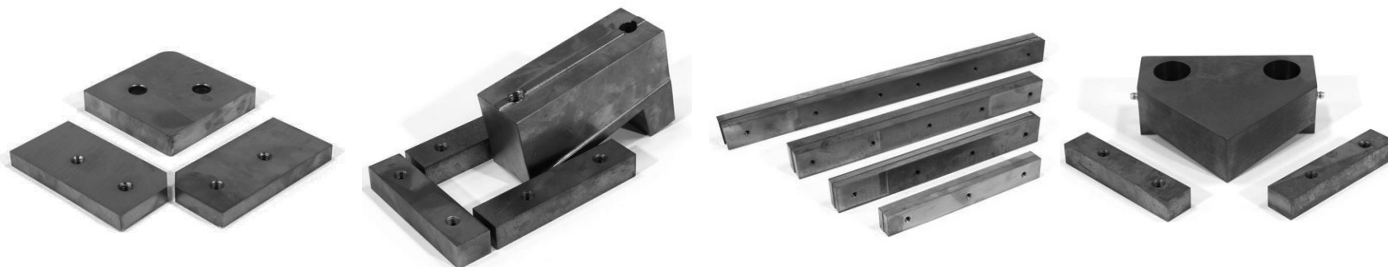



Piranha™ Ironworkers

Model	Punch	Die
P-2	219	413
P-3	219	413
P-36	219	413
P-4	228	419
P-40	219	413
P-50	219	413
P-65	219	413
P-70	228	419
P-90	228	419
P-120	228	419
PII-35	219	413
PII-65	219	413
PII-88	228	419
PII-110	228	419
PII-140	228	419
SEPP-35	219	413
SEPP-65	228	419
SEPP-88	228	419
SEPP-120	228	419
SEPP-140	228	419

Note: Piranha™ Ironworkers use Punch Style 228 and 28XX and Die Style 419 and 28XX for Oversize Hole Punching.

PUNCHES

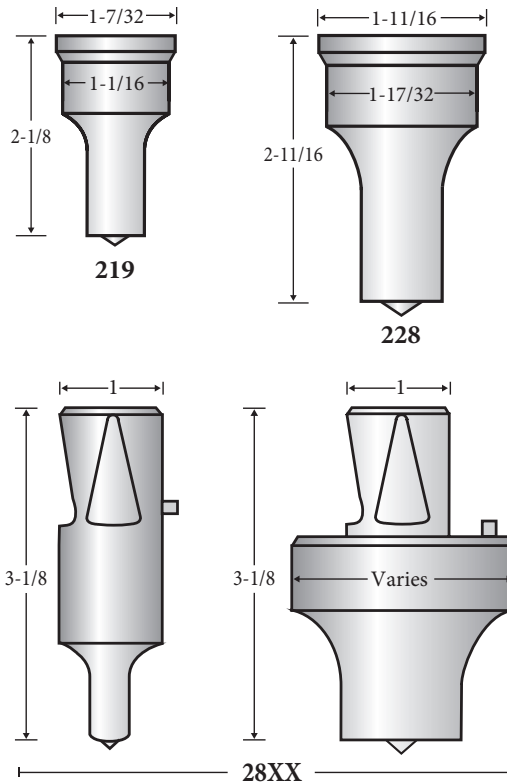

See page 14 for more information on 28XX punches

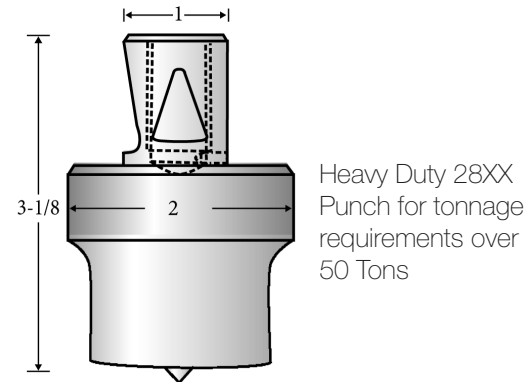
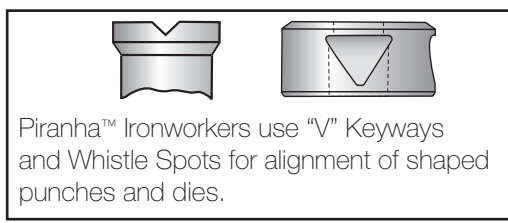

DIES

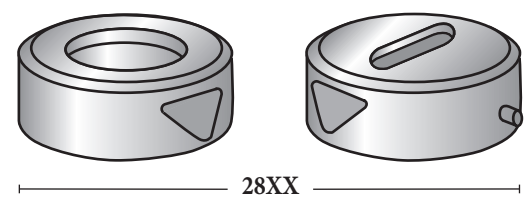
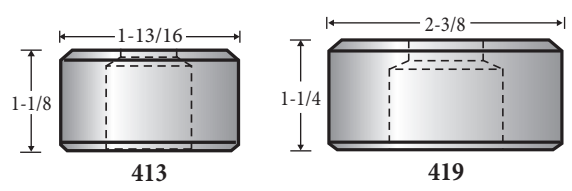

See page 14 for more information on 28XX dies.

Piranha™

Piranha™ Ironworkers

MISCELLANEOUS TOOLING

Coper Notcher

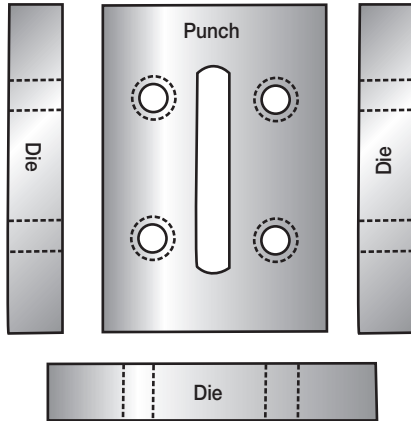

Coupling Nut

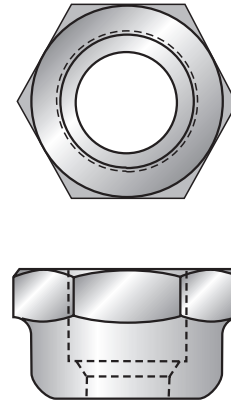

Punch Stem

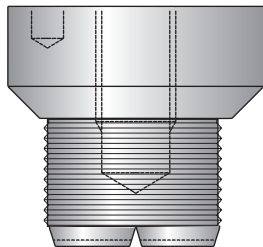

Urethane Stripper

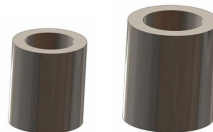

Bar Cutter Knife

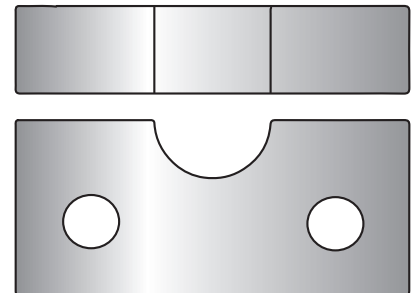

SHEAR BLADES

Flat Bar Shear Blades

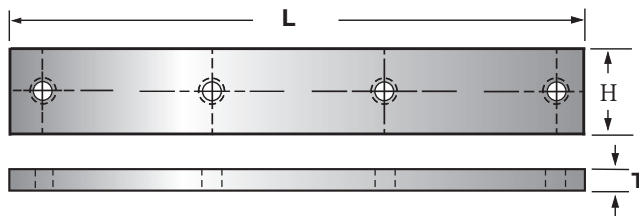

Reversible with four (4) cutting edges.
Two (2) required.

Angle Shear Blades

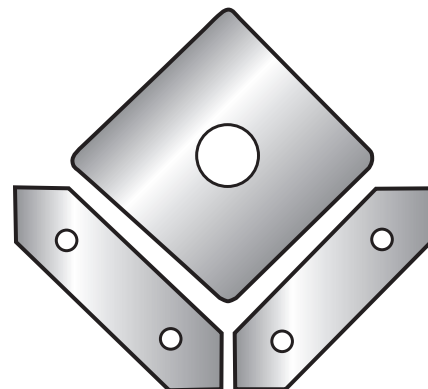

Reversible with (2) cutting edges.



Scotchman™ /Dvorak™ Ironworkers

Model	Punch	Die
207	DVP	DVD
314	DVP	DVD
314C6	DVP	DVD
314T	DVP	DVD
516	DVP	DVD
424	DVP	DVD
2450	221	417
3209	DVP	DVD
4014	DVP	DVD
4014C	DVP	DVD
4014 CM	DVP	DVD
4014T	DVP	DVD
4060B	DVP	DVD
5014	DVP	DVD
5024	221	417
5075	221	417
6012	221	417
6023	221	417
6509	221	417
7012	221	417
7575	221	417
9012	221	417
9075	221	417
12012	221	417
50514 CM	DVP	DVD
DO-70	221	417
DO-100	221	417
FI-5009	221	417
FI-5109	221	417
FI-6008	221	417
FI-8507	221	417

PUNCHES

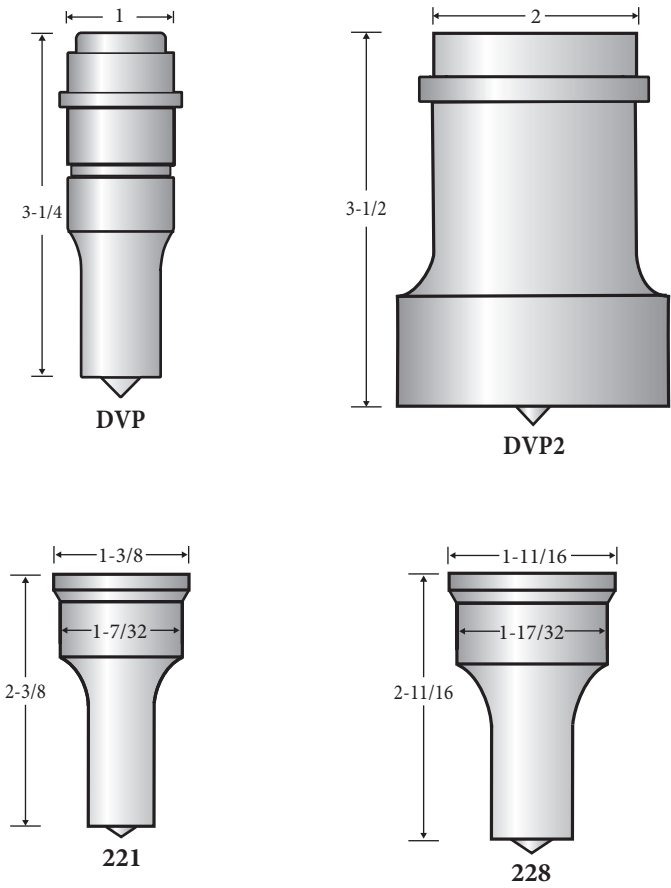

Note: Scotchman™ and Dvorak™ Ironworkers use Punch Style DVP2 or 228 and Die Style DVD2, 420, 422, or 6 x 6 Die Block for Oversize Hole Punching.

Scotchman™ /Dvorak™

DIES

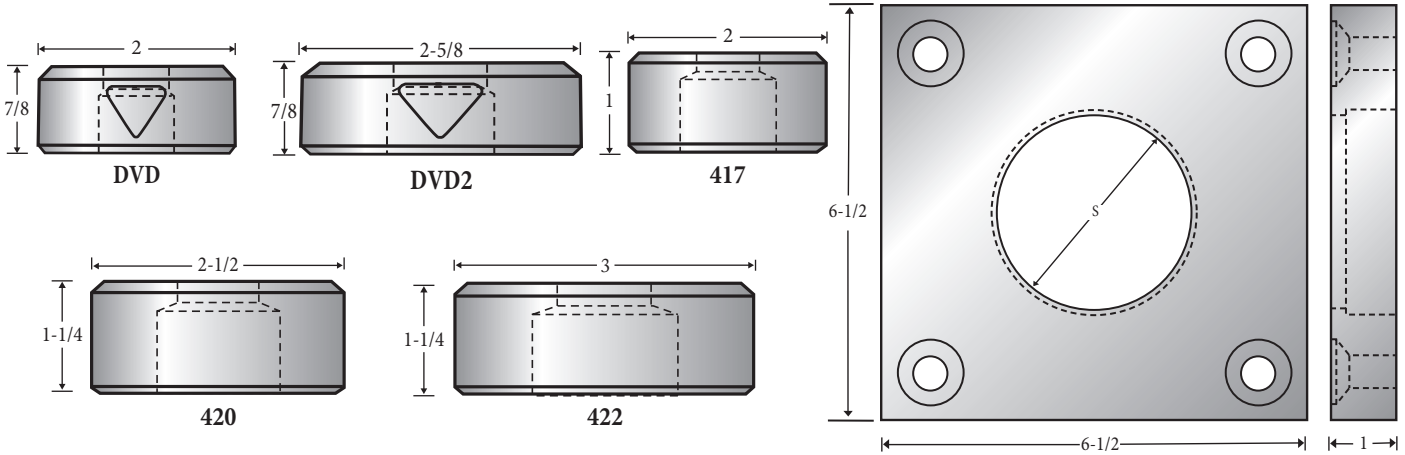

Scotchman™ /Dvorak™ Ironworkers

COUPLING NUTS

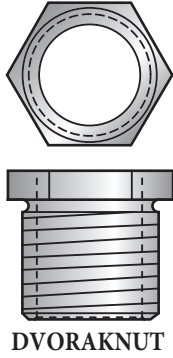

Part #	Fits Punch
CNUT22SC1	221
CNUT22SC2	228
DVORAKNUT	DVP

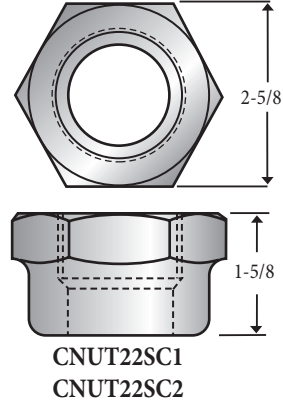

SHEAR BLADES

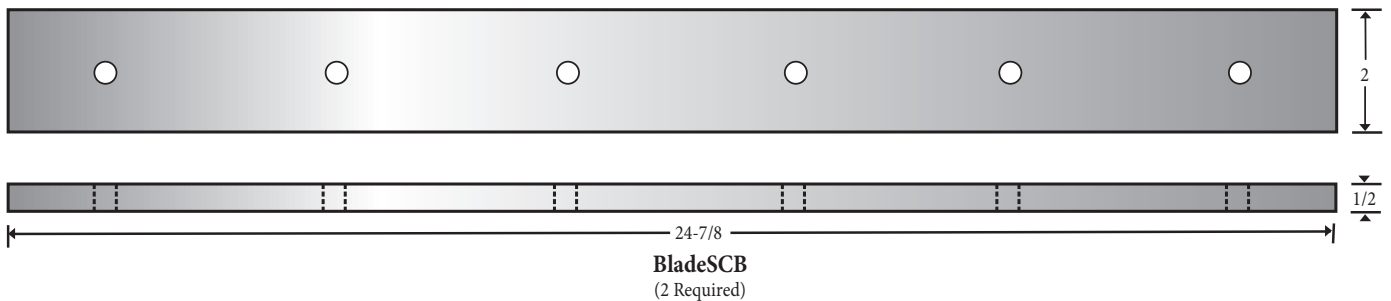
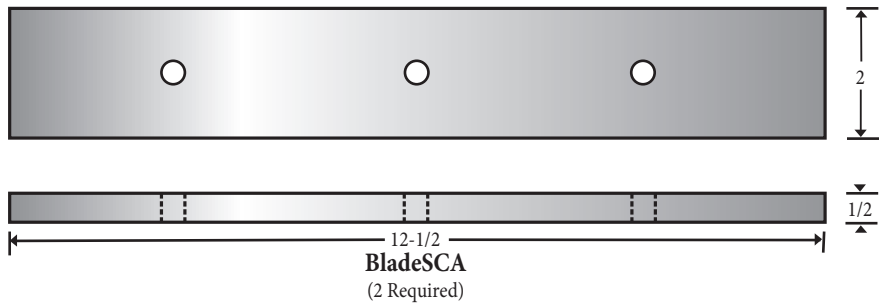
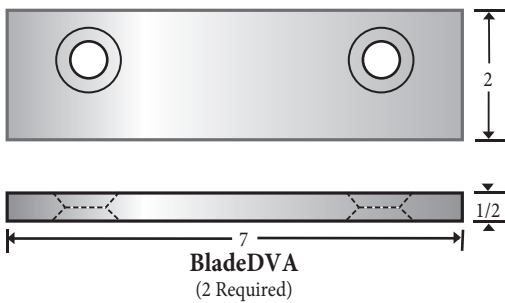
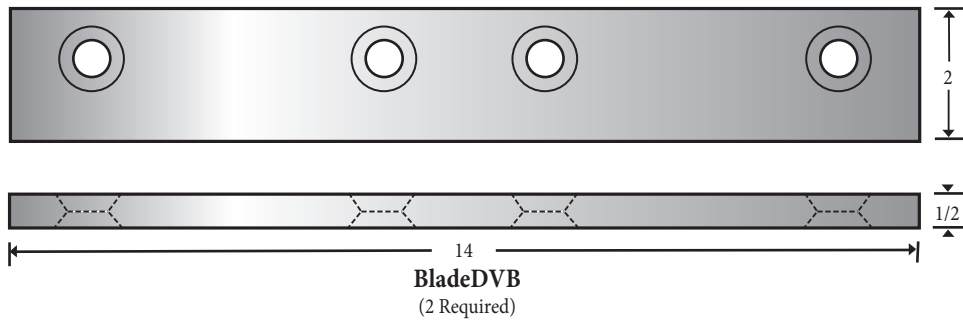

Scotchman™ /Dvorak™



Spartan™/Brobo™ Ironworkers

Model	Punch	Die
IW50	221	413
IW50S	221	413
IW66D	221	413
IW66S	221	413
IW88D	221	413
IW94/120D	228	419
IW110D/2	228	419
IW135D	228	419
IW180DX	228	419

Note: Spartan™/Brobo™ Ironworkers use Punch Styles 228 or 51mm - 100mm and Die Style 419 or 80mm - 250mm for Oversize Hole Punching.

PUNCHES

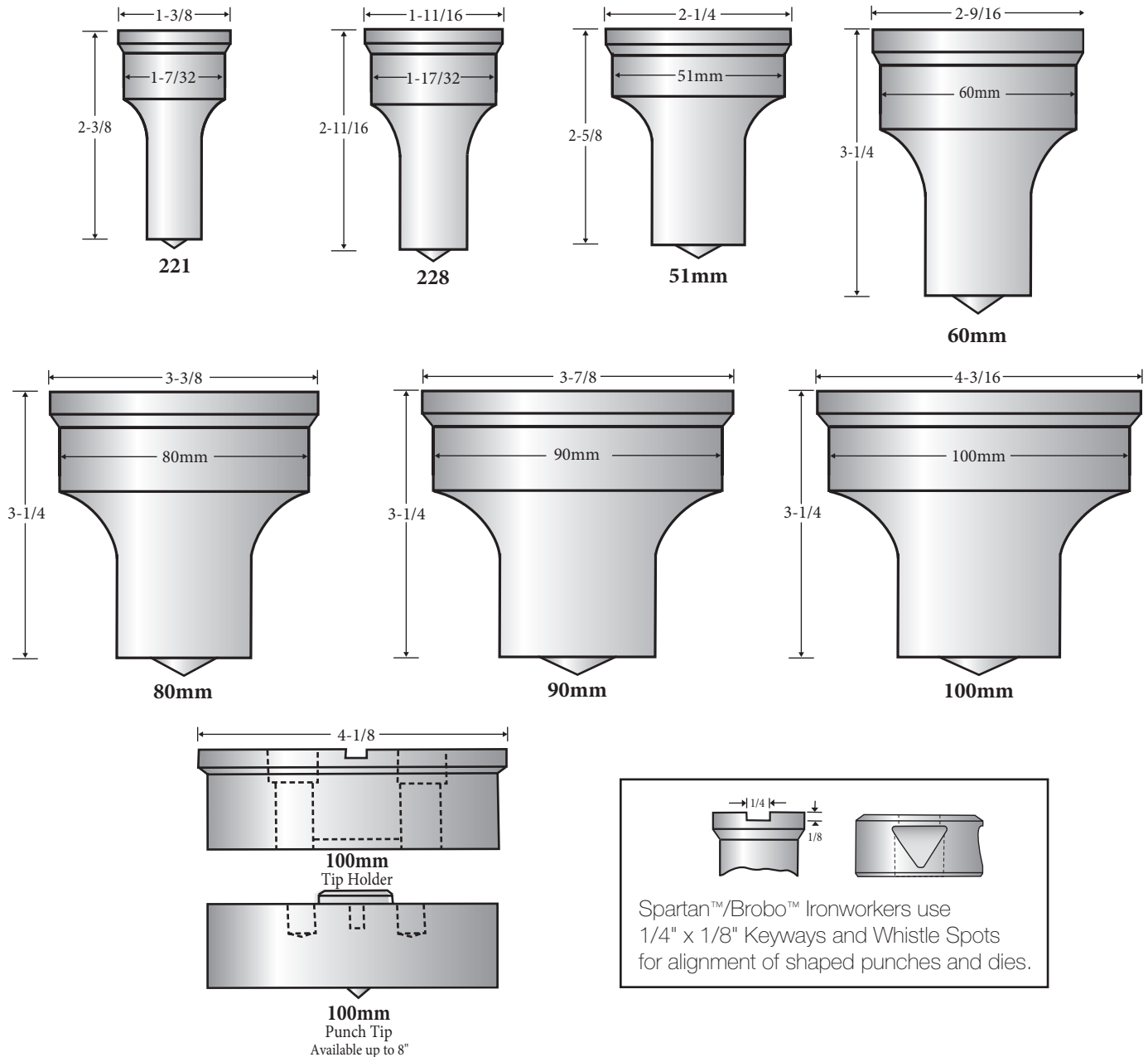

Spartan™/Brobo™

Spartan™ / Brobo™ Ironworkers

DIES

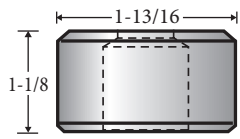

413

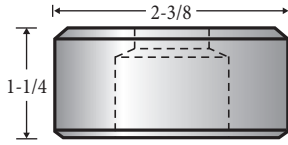

419

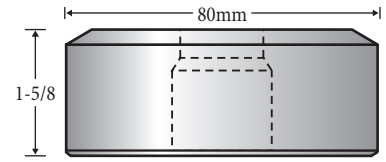

80mm

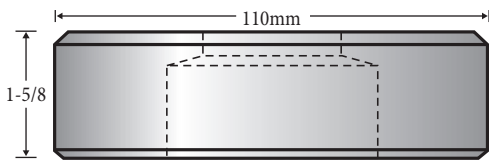

110mm

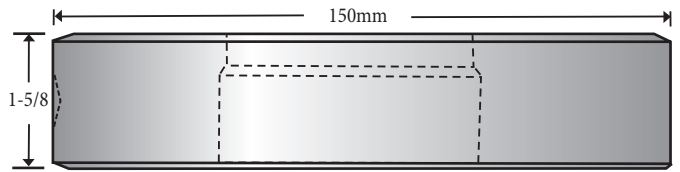

150mm

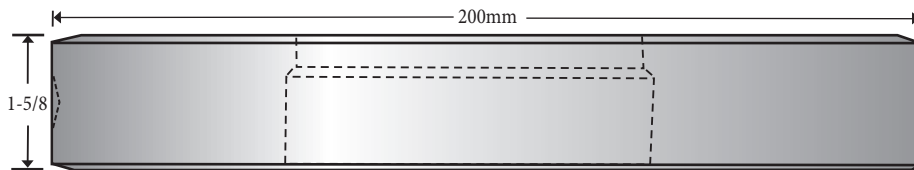

200mm

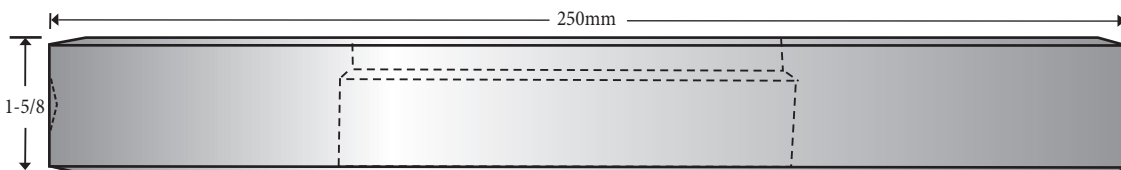

250mm

SHEAR BLADES

We manufacture Shear Blades for all types of Ironworkers and can custom manufacture to your specifications.





Sunrise™ Ironworkers

Model	Punch	Die
IW-50K	SUN30P	SUN45D
IW-66K	SUN30P	SUN45D
IW-66KB	SUN30P	SUN45D
IW-95KD	SUN30P	SUN45D

Note: Sunrise™ Ironworkers use Punch Style Sun40P or Sun51P and Die Style Sun60D or Sun80D for Oversize hole requirements.

PUNCHES

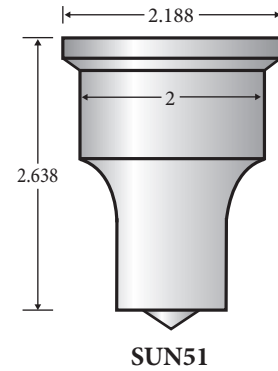
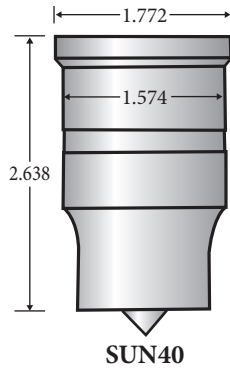
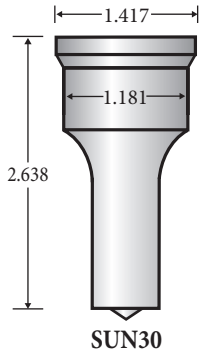

DIES

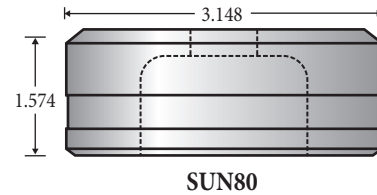
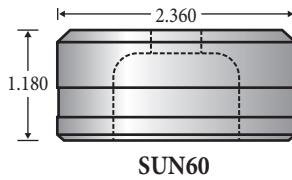
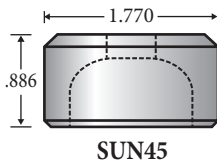

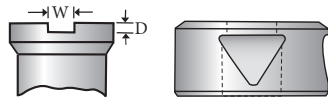

Sunrise™ Ironworkers use 4mm x 2mm Keyways and Whistle Spots for alignment of shaped punches and dies.

SHEAR BLADES

Flat Bar, Angle, Coper or Angle Notcher, Bar Cutter and all other Shear Blades are available.

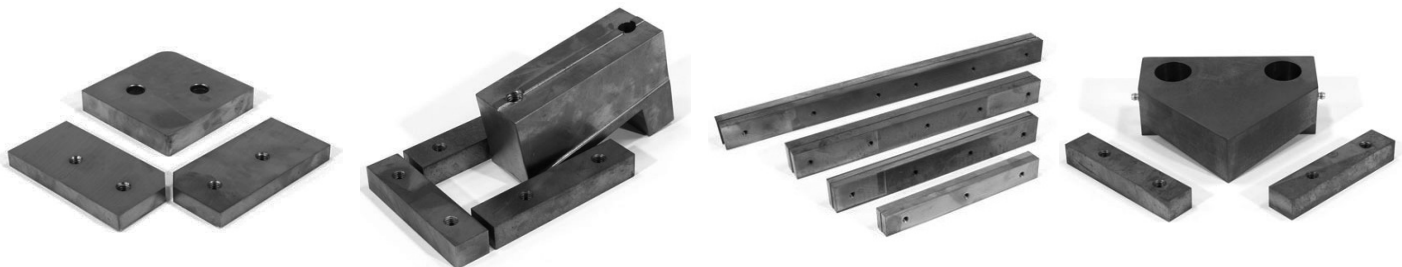

Sunrise™

Uni-Hydro™ Ironworkers

Model	Punch	Die
All Models	UHP	UHD

Note: Uni-Hydro™ Ironworkers use Punch Style UHP2 or 237 and Die Style UHD2, 422 or 490 for Oversize Hole Punching.

PUNCHES

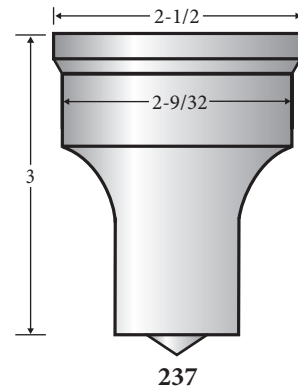
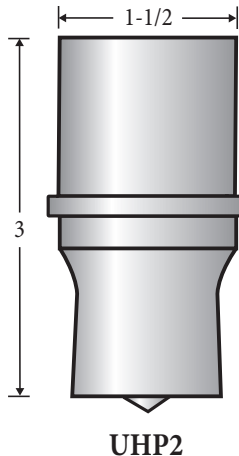
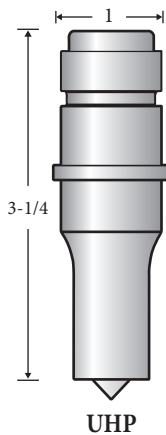

DIES

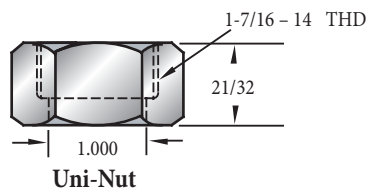
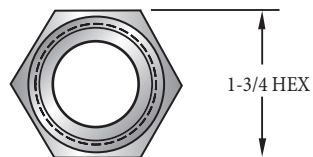
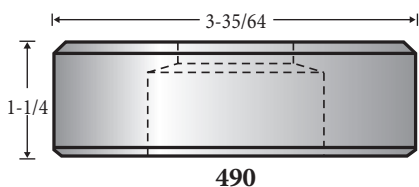
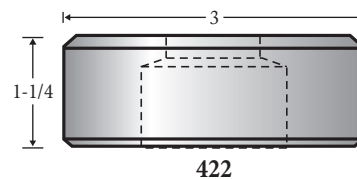
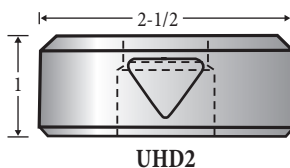
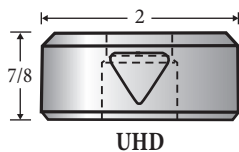

SHEAR BLADES

We manufacture Shear Blades for all types of Ironworkers and can custom manufacture to your specifications.





W.A. Whitney™ Machines

Model	Punch	Die
606	28XX	28XX
609	28XX	28XX
610	28XX	28XX
612	28XX	28XX
613	28XX	28XX
615	28XX	28XX
625	28XX	28XX
626	28XX	28XX
627	28XX	28XX
630	28XX	28XX
635	28XX	28XX
637	28XX	28XX
647	28XX	28XX
647 ATC	36TC™	36TC™
647 Plus	36TC™	36TC™
647 Plus II	36TC™	36TC™
650	28XX	28XX
652	28XX	28XX
653	28XX	28XX
655	28XX	28XX
656	28XX	28XX
661-120	36TC™	36TC™
661-60	36TC™	36TC™
661-84	36TC™	36TC™
661-84 ATC	36TC™	36TC™
661-96 ATC	36TC™	36TC™
705	61	49
710	62	48
710CC	62	49
720	62	48
720X4	62	48
720X6	62	48

Note: W.A. Whitney™ machines use Punch Style 64XX or 66 and Die Style 47XX for Oversize Hole Punching.

PUNCHES

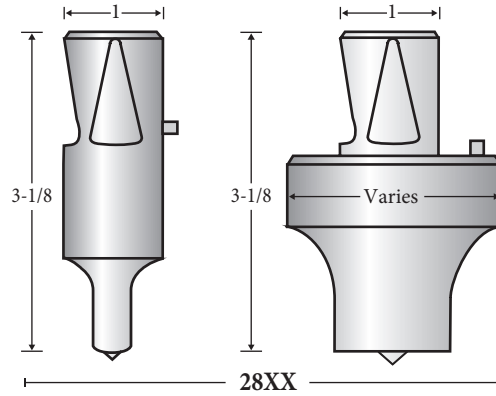

See page 14 for more information on 28XX punches.

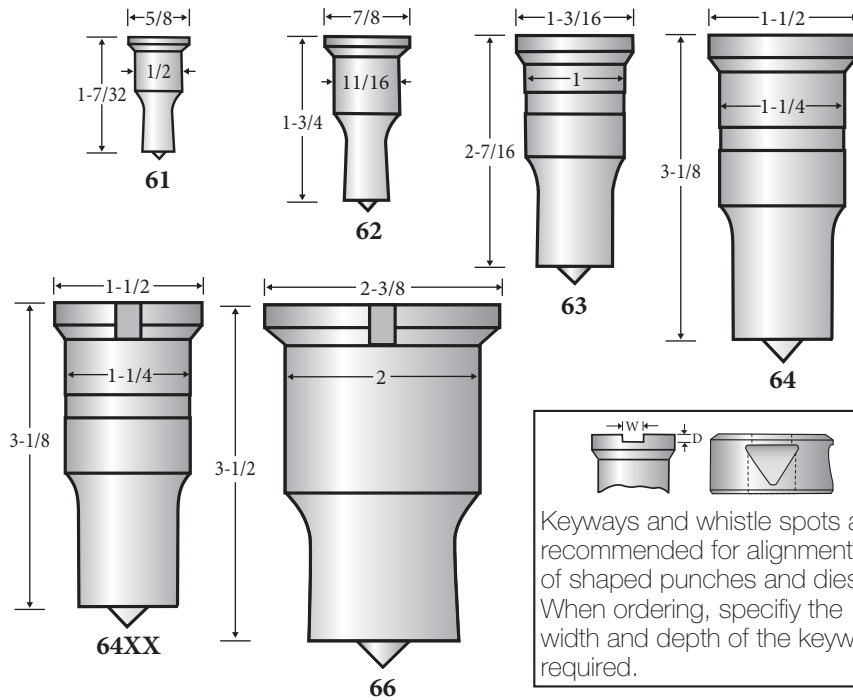

W.A. Whitney™

36TC™ PUNCHES

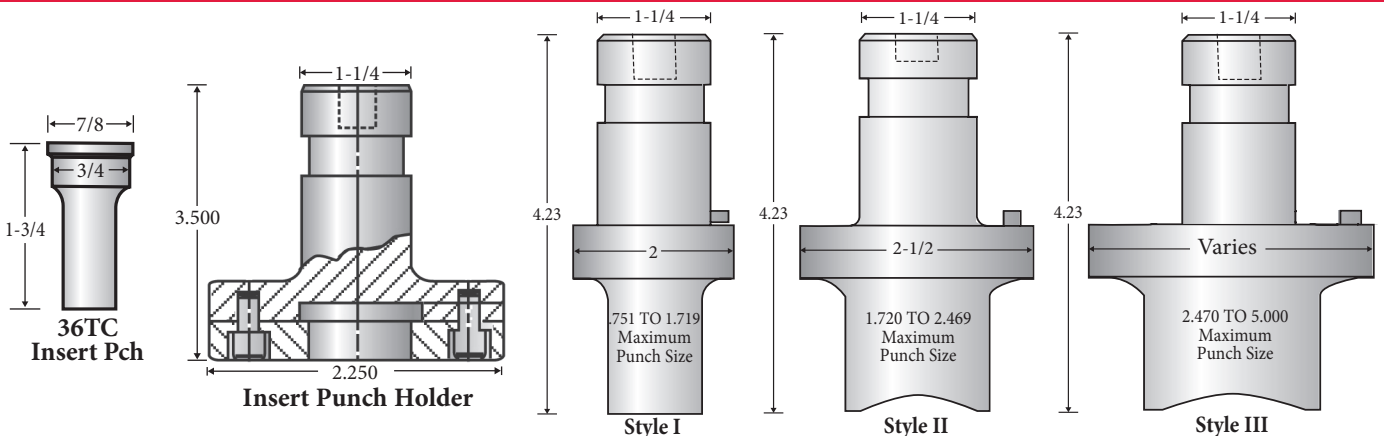

W.A. Whitney™ Machines

Model	Punch	Die
721	62	48
730	63	47
730CC	63	48
730X8	63	47
730X8CC	63	48
731	63	48
750	63	47
750AX6	64	47
751	63	47
751AX7	64	47
770	64	47
771	64	47
771AX9	64	47
790	64	47
790AX6	64	47
791	64	47
791AX18	64	47
791AX30	64	47
791X18	64	47
796 Beamline	64	47XX
845 Anglematic	64	47XX
1524	28XX	28XX
2120	28XX	28XX
2330	28XX	28XX
2530	28XX	28XX
2548	28XX	28XX
7130-60	64	47XX
7150AX12	64	45
7150AX6	64	46
7151AX12	64	46
7250AX12	66	45

DIES

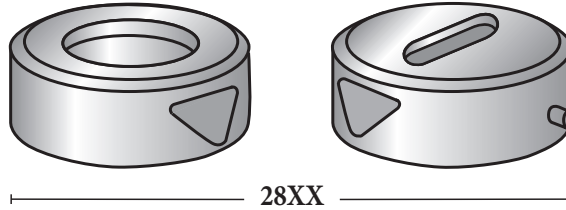

See page 14 for more information on 28XX dies.

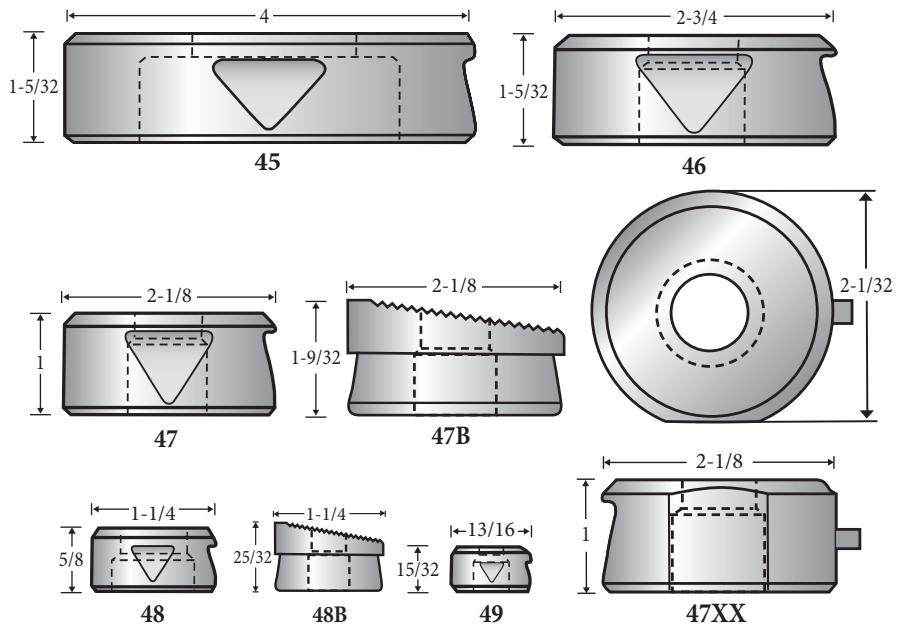

Note: W.A. Whitney™ machines use Punch Style 64XX or 66 and Die Style 47XX for Oversize Hole Punching.

36TC™ DIES

Note: Standard locating pin position on shaped dies

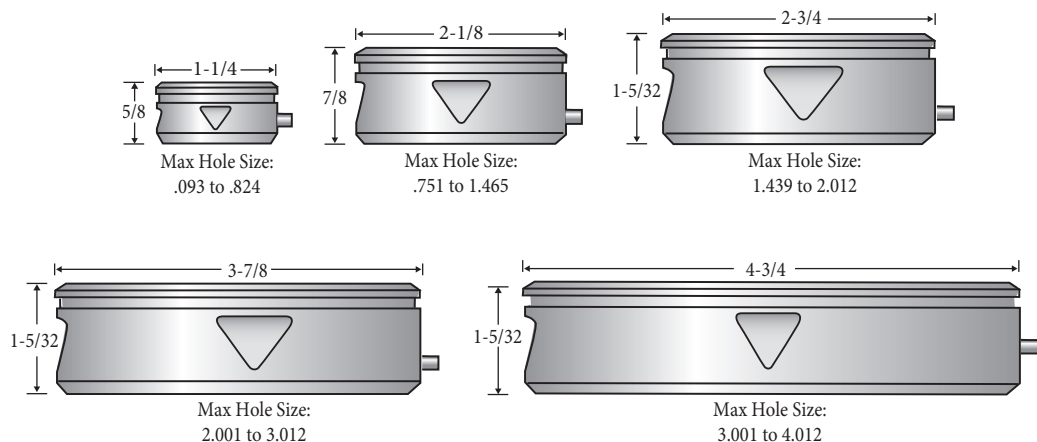
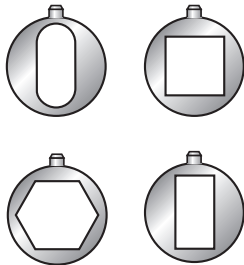



W.A. Whitney™ Machines

DIE ADAPTERS

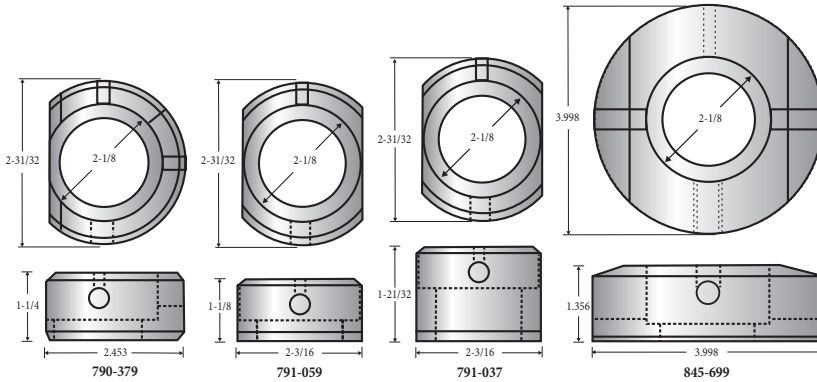

Die Adapter	Die Dia.	Die Clamp	Die Pin
636-381	1-1/4"	630-268*	N/A
636-382	2-1/8"	630-269*	N/A
636-436	2-3/4"	N/A	636-604
636-437	3-3/4"	N/A	636-605
636-438	4-3/4"	N/A	636-606
845-699	2-1/8"	N/A	N/A

*Uses 630-271 adapter screw.

COUPLING NUTS

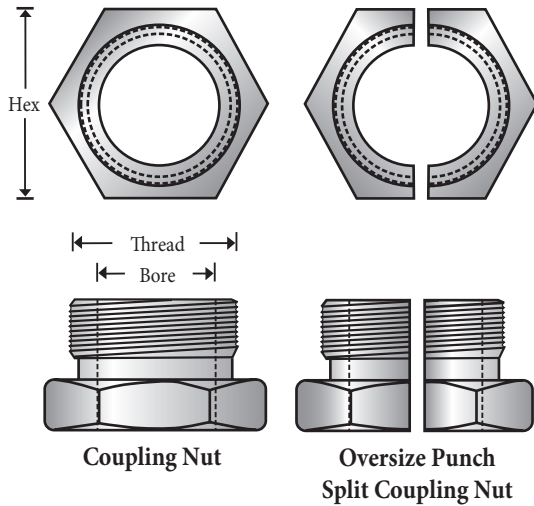

Part No.	Thread	Bore	Hex	Punch
CNUT62	16, 1"	11/16"	1"	62
CNUT63	12, 1-3/8"	1"	1-3/4"	63
CNUT64	12, 1-3/4"	1-1/4"	2"	64
790-061	12, 1-3/4"	1-1/4"	2"	64
845-689	12, 1-3/4"	1-1/4"	2-1/16"	64

Note: Threads are right hand

Call or visit our website for information on
Punch Stem Adapters for W.A. Whitney™ Machines.

SHEAR BLADES

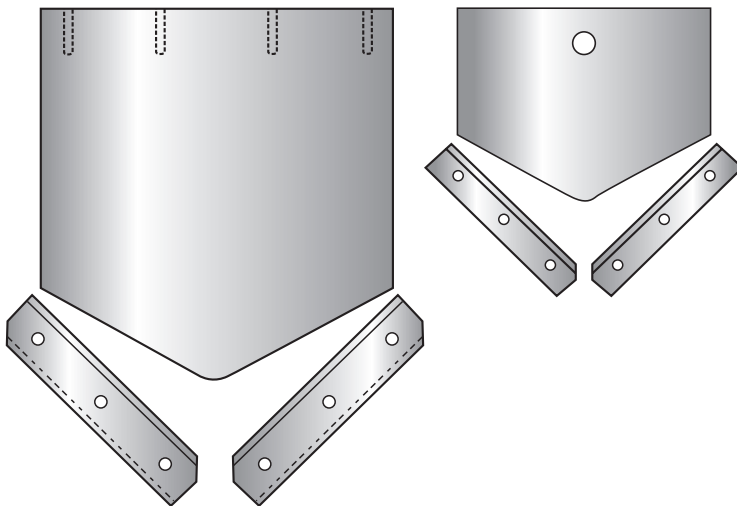

Model	Upper Shear Blade	Lower Shear Blade
606	606-008	606-010 (2) Left 606-113 (2) Right
609	609-004	609-039 (2) Left 609-040 (2) Right
664	664-061	609-039 (2) Left 609-040 (2) Right
764	664-061	609-039 (2) Left 609-040 (2) Right
765	765-036	765-032 (4)
845	609-004	845-269 (2) Right 845-270 (2) Left

Punch Cross Reference Chart

Punch Style	CPD Number	AP Number	P/W Number
11	F-GOS1	11	XB
12	F-GOS2	12	XW
13	F-GOS3	13	XX
13 (2 Pcs)			XY
28XX	F-2801-2805	100XX	28XX
28XXHD		10434	
36TC	C00XP	1PTC	
36TC	C10XP	1TC	
36TC	C20XP	2TC	
36TC	C30XP	3TC	
51mm	SP51P		TU
60mm	SP60P		TV
61	C-232		710
62	C-242		720
63	C-740	163	740
64	C-770	164	770
64XL	C-FP1		
64XX	C-790F (F-790XX)	164XX	790XX
64XXL	C-790FXL		
64Y	C-274		
65	C-282	165	PY
66	C-7501	166	7501
67	C-400	167	UP
80mm	SP80P		TW
90mm	SP90P		TX
100mm	SP100P		TY
100mm Tip Holder	SP100PEO		RU
207	F-6	107	PW
208	F-7	108	PX
209			
212	F-9	112	
214			
216	F-12	116	DE
217			
218	F-15	118	RV
219	F-16	119	DH
220	F-17	120	RX
221	F-20	121	EA
222	F-19	122	RZ
223	F-21	123	SR

Punch Style	CPD Number	AP Number	P/W Number
228	F-26	128	EF
228S	F-26S	128S	SX
233	F-30		TP
237	C-50	137	VP
238			
239	C-53		VT
241		141	WV
292	C-292		PZ
75001	C-001		
75002	C-002		
75002.5			
75003L	C-003		
75003S			
75004	C-004		
75004PR			
75005	C-005		
75006	C-006		
75006PR			
76000PR			
BF10	BF10	BF10	PV
BNP	F-158		BJ
BNP-O			
DVP	SR-20	190	BF
DVP2	SR-150	190-N	SP
H-1	H-1	119M H1	DH
H-2	H-2	121M H2	EA
H-3	H-3	A3	VX
H-4	H-4	A4	VY
H-5	H-5	A5	VZ
HUSPCH	F-5	105	
NKP	F-13	192	
NKP-0			
P36	F-9	3620	FF
P3T	F-3T-10220	3T10	FJ
P66	F-664	6640	
P90	F-20 (903)	9030	
SUN30P		SP-1	
SUN40P		SP-2	
SUN51P		SP-3	
UHP	SR-20	190	BF
UHP2	SR-200	190-A	VR



Die Cross Reference Chart

Die Style	CPD Number	AP Number	P/W Number
11	F-GOS1	11	XZ
12	F-GOS2	12	YP
13	F-GOS3	13	ZR
28XX	F-2810	100XX	28XX
28XX	F-2811	100XX	
28XX	F-2812	100XX	
28XX	F-2813	100XX	
28XX	F-2814	100XX	
28XX	F-2815	100XX	
36TC		114TC	
36TC		218TC	
36TC		234TC	
36TC		334TC	
36TC		434TC	
45	C-7602	345	7602
46	C-7502	346	7502
47	C-271	347	740
47B	C-740	347BC	740BS
47F	C-271F	347F	
47XX	C-790XX	347XX	790XX
47/45	C-273	347F/45	
48	C-720	348	720
48B	C-720		720BS
49	C-710		710
60mm	F-62S	360	WT
80mm	SP80D	380	YT
90mm	C-91MM	390	
110mm	SP110D		YU
150mm	SP150D		YV
200mm	SP200D		YS
250mm	SP250D		YW
291	C-291FS	391	UW
402	F-41		HC
405	F-43	305	UT
407	F-45		UV
408	F-46	308	HH
411			
413	55	313	JB
417	F-59	317	JC
418	F-60	318	WP

Die Style	CPD Number	AP Number	P/W Number
419	F-62	319	JF
419/45	C-293F	319/45	
420	F-65	320	JG
421	C-89	321	JK
422	F-71	322	XR
423	C-92		ZS
424	F-72		XS
490	C-91MM	390	ZR
75001	C-001		
75002	C-002		
75003L	C-003		
75003S			
75004	C-004		
75004PR			
75005	C-005		
75006	C-006		
76000PR			
BND	F-46		
D12			
D14	F-201	1400	KK
D66	F-202	6650	BA
D85	F-200	8530	KJ
D90	F-203	9040	BB
DVD	F-59	351A	BG
DVD-2			RS
H-1	H-1	313M H1	
H-2	H-2	317M H2	
H-3	H-3	A3	
H-4	H-4	A4	WR
H-5	H-5	A5	WS
HUSDIE	F-44	244	
MD86			
NKD	F-51	352	
NKDB		352BC	
SUN45D		SD-1	
SUN60D		SD-2	
SUN80D		SD-3	
UHD		351	
UHD-2		353	

Custom Tooling

Let Us Help You Solve Your Problem

Cleveland Steel Tool specializes in custom solutions to your punching problems. If you need special tooling, special sizes, or a custom die set our sales engineers can design the solution for your unique environment. See the examples below:

A customer in the conveyor industry needed to crimp “ears” onto a spindle for a conveyor.

A Special crimping punch and die quickly creates repeatable crimps.



An automotive industry customer wanted to emboss their brand name onto their finished assemblies.

A punch and die set with a raised logo and then recessed mirror image allows rapid embossing of the brand name.



A builder of steel frame structures needed to flatten and trim the ends of pipe, and punch a bolt hole to attach sections.

In two strokes the die set cuts the radius, crimps the end, and punches the hole.

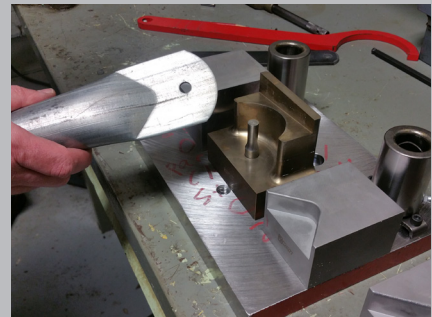

A leaf spring manufacturer needed to upgrade and replace their aging die holder.

The original die block was reverse engineered, new attachment and retention points were added and the die block was replaced.

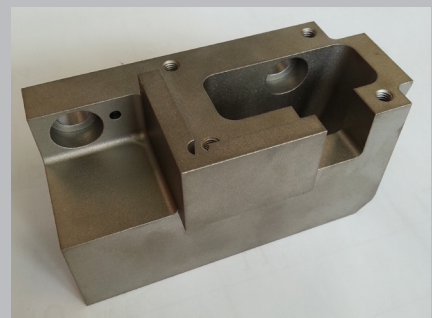



Custom Tooling

Improve Productivity with a Custom Die Set

A die set is often used to combine two or three operations into one, reducing cycle and setup times, and improving repeatability. In addition to the examples shown, we offer picket tools for fence pickets, corner rounding tools, pipe notching die sets and much more. Call us, or send us your part, and we'll create an efficient solution.

A manufacturer of files needed to form the tang (handle) using less machining time.

In a single stroke, the die set punches out the handle completely to size.

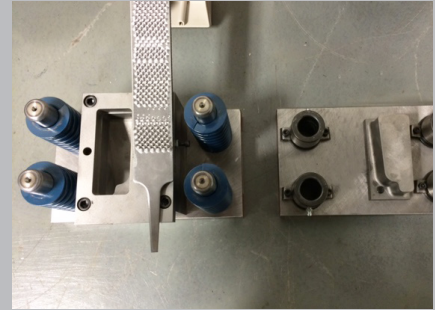

A packaging equipment manufacturer wanted to streamline the manufacture of blades for cutting poly bags.

The triple oblong die set puts three holes at once into 20 gauge spring steel to form the mounting holes for the cutting blades.

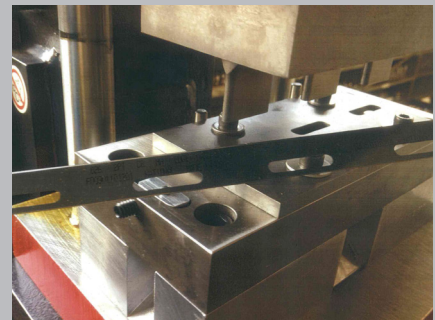

A supplier to the sporting goods industry needed to build retaining brackets for a boxing ring.

CST engineers created a double bar bend attachment to make consistent, repeatable bends and streamline production.

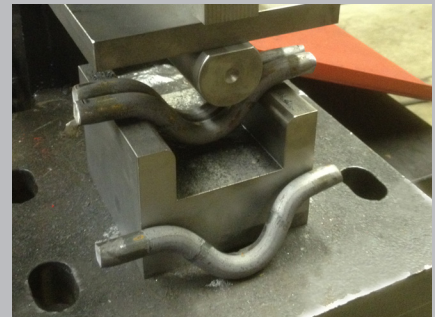

An equipment manufacturer sought to minimize handling and reduce the time needed to put the four mounting holes into the baseplate of their machine.

With the four hole punch die set, the square plate is always properly aligned and the four holes are punched in one stroke and always with the perfect spacing.

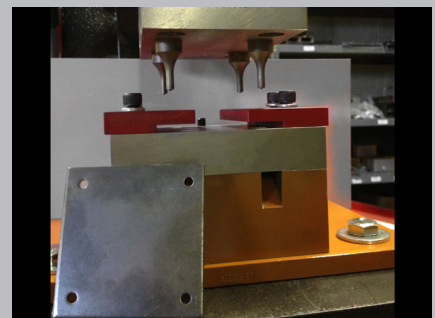

Portable Punching Unit



35 Ton Porta Punch

Punch up to 13/16" round and 9/16" square holes in 3/8" thick mild steel on the spot.

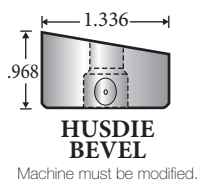
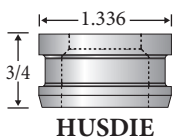
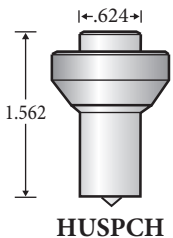

Scan to view our Porta Punch in action.

Our 35-Ton Porta-Punch™ weighs just 31 pounds, is easy to use and punches in seconds. The dual-action stripper holds the material being punched and then strips the material from the punch so you're ready for the next hole in seconds. It is ideal for punching bus bars, tower iron, railing, I-beams and truck frames. Mount to your work bench or take it to the job site.

FEATURES

- Operates from any 10,000 psi hydraulic source (electric hydraulic pump available from CST – below).
- Metal carrying case included for easy portability.
- Shaped punches and dies available in 24 hours.
- Easily mounts to a workbench for production jobs.
- 3/8" female coupler attached for quick disconnect.
- One year warranty against manufacturing defects.
- Oblong, square, hex and rectangular tools are available in 24 hours.

C-FRAME SPECIFICATIONS

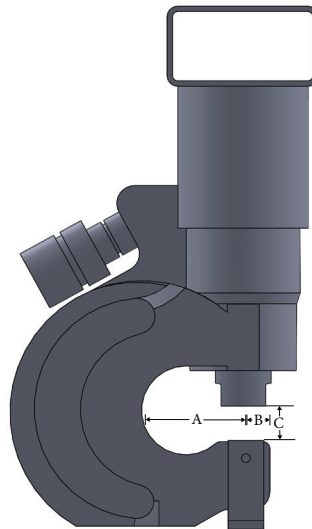

Tonnage	35 Tons
Max Round	13/16" thru 3/8"
Max Square	9/16" thru 3/8"
Weight	31 pounds
Throat Depth (A)	2-3/4"
Gauge Length (B)	15/16"
Open Height (C)	9/16"
Dimensions	14" x 7" x 3-3/4"

PUMP SPECIFICATIONS

- Motor Size: 1 HP, 115 volt
- Delivery @10,000 psi: 19 In. ³/_M
- Oil Capacity: 1 Gallon
- Weight: 70 lbs.
- Dimensions: 8" x 10-1/2" x 16"
- Plugged into any 110v outlet.
- Includes 10' high pressure hose with couplers.
- Attached 3/8" high pressure quick-disconnect coupler.



Magnetic Drilling Machines

SPECIFICATIONS

Model	EVOMAG28	EVOMAG42	EVOMAG50	EVOMAG75	JHMUSA5
Motor	120v, 1,200 Watts	110v, 1,200 Watts	120v, 1,700 Watts	120v, 1,700 Watts	1,400 Watts
Speed (No Load)	570 RPM	450 RPM	380-500 RPM	200, 260, 390, 490 RPM	330/660 RPM
Maximum Twist Drill Diameter	1/2"	1/2"	5/8"	1-1/4"	3/4"
Maximum Cutter Diameter	1-1/8"	1-5/8"	2"	3"	2-3/8"
Maximum Cutting Depth	2"	2"	3"	2"	3"
Cutter Shank Diameter	3/4" Weldon Shank	3/4" Weldon Shank	3/4" Weldon Shank	3/4" Weldon Shank	3/4" Weldon Shank
Magnetic Holding Power 3/8" plate	2,860 lbs.	2,860 lbs.	7,194 lbs.	7,194 lbs.	2,473 lbs.
Weight	38 lbs.	26 lbs.	55 lbs.	54 lbs.	53 lbs.
Dimensions	23" h x 8-7/8" w	25-3/4" h x 8-3/4" w	24" h x 8-1/2" w	24-1/4" h x 8-1/2" w	23-5/8" h x 8-1/2" w

Machines shown without permanent safety guard for marketing purposes only.



EVOMAG28

Mag Drills Feature

- Coolant system with internal cutter lubrication
- Safety Chain
- Full safety guard system
- Carrying Case
- 3 Year Warranty



EVOMAG42



EVOMAG50



JHMUSA5



Scan to view our
Magnetic Drills
on our website.



EVOMAG75

Annular Cutters

HIGH SPEED STEEL CUTTERS

Our 3/4" Weldon shank cutters fit most common magnetic drills, including Hougen™, Jancy™, Evolution™, Fein™ and Milwaukee™.

Metric sizes, Carbide tipped, ID (Stacked) Geometry, Countersink and 4" and 6" depth of cut also available.



Center Pins included with all cutters.

Cutter Size	1" Depth Stock Part #	2" Depth Stock Part #	3" Depth Stock Part #
7/16	H4375	HL437	
1/2	H5000	HL500	
17/32	H5310	HL531	
9/16	H5625	HL562	
5/8	H6250	HL625	
21/32	CC21/32	HL687	
11/16	H6875	HL750	CC687X
3/4	H7500	HL812	7500H
13/16	H8125	HL875	8125H
7/8	H8750	HL937	8750H
15/16	H9375	HL100	9375H
1"	H1000	HL106	1000H
1-1/16	H1062	HL112	1062H
1-1/8	H1125	HL119	1125H
1-3/16	H1187	HL125	1187H
1-1/4	H1250	HL131	1250H
1-5/16	H1312	HL137	1312H
1-3/8	H1375	HL143	1375H
1-7/16	H1437	HL150	1437H
1-1/2	H1500	HL156	1500H
1-9/16	H1562	HL162	1562H
1-5/8	H1625	HL168	1625H
1-11/16	H1687	HL175	1687H
1-3/4	H1750	HL181	1750H
1-13/16	H1812	HL187	1812H
1-7/8	H1875	HL193	1875H
1-15/16	H1937	HL200	1937H
2"	H2000	HL206	2000H
2-1/16	H2062	HL212.75H	2062H
2-1/8	H2125.75H	HL218.75H	2125H.75H
2-3/16	H2187.75H	HL225.75H	2187H.75H
2-1/4	H2250.75H	HL231.75H	2250H.75H
2-5/16	H2312.75H	HL237.75H	2312H.75H
2-3/8	H2375.75H	CC250L	2375H.75H
2-1/2		CC262L	
2-5/8		CC262L	

Center Pins are included with all cutters.

Steel Saws and Saw Blades

STEEL SAWS

Our saws are quicker, safer, more accurate and economical than competitive models or abrasive saws. Cut mild steel without excessive heat, sparks, burrs or the necessity of coolant.

7-1/4" Steel Circular Saw



The 7-1/4" saw, for plate, tube or angle, offers a 0- 45° bevel and adjustable depth of cut to out-perform angle grinders.

9" Steel Circular Saw



The 9" saw, ideal for plate, pipe or metal roofing, features a laser guide, bevel feature and adjustable depth of cut.

15" Steel Circular Saw

The 15" chop saw cuts cleanly, without excessive heat, burrs or coolant, features a 45° fast action swivel clamp, and outlasts abrasive discs.



Saw Blade included with each steel saw.

SAW BLADES

Our standard saw blades are the finest steel cutting blades on the market.

Our saw blades are designed to deliver maximum performance by using the highest grade carbide, hardened blade bodies and ultra high grade brazing techniques.



Specialty saw blades include

- thin steel
- stainless
- aluminum
- diamond
- wood
- masonry
- multi-purpose

Saw blades are available for almost any industrial saw manufacturer, including:

Evolution, Milwaukee, Jancy, Bosch, MK Morse, Steelmax, Dewalt, Makita

Our Mild Steel Saw Blades can cut through 6" of 1/4" mild steel in as little as 12 seconds. Carbide Steel Blades are faster, cooler, more accurate and longer lasting than abrasives.

40 Ton and 50 Ton Ironworker

40 TON – THE SHOPMATE

4 Workstations – Maximum capacity: 1" diameter in 1/2" plate

Punching Station

Throat depth: 7"
Stroke: 1"
Largest Standard Punch: 1-1/16"
Work Height: 38-1/2"

Open Station

Throat depth 7-3/4"
Stroke 1-3/8"
Work Height 35-3/4"

Angle Shear

3" x 3" x 1/4"
Work Height 52-1/2"

Flat Bar Shear

3/8" x 10"
1/2" x 6"
Work Height 33-1/2"

Motor

5 HP, 1 or 3 phase, 208V-575V

Dimensions

32"w x 23"d x 60-1/2"h, 1,900 lb



50 TON – COMPACT AND VERSATILE

4 Workstations – Maximum capacity: 1" diameter in 5/8" plate

Punching Station

Throat depth: 7"
Stroke: 1-15/16"
Largest Standard Punch: 1-1/16"
Work Height: 36-9/16"

Angle Shear

3" x 3" x 3/8"
Work Height 39-7/8"

Flat Bar Shear

1/2" x 10"
3/4" x 4"
Work Height 39-7/8"

Coper Notcher

Max. Capacity 2" x 3" x 5/16"
Work Height 39-1/2"

Motor

5 HP, 1 or 3 phase, 208V-575V

Dimensions

36-3/4"w x 36-1/8"d x 54-1/2"h, 2,020 lb





55 Ton and 60 Ton Ironworker

55 TON – OUR BEST SELLER

4 Workstations – Maximum capacity: 1-1/16" diameter in 5/8" plate

Punching Station

Throat depth: 7-1/2"
Stroke: 1-1/4"
Largest Standard Punch: 1-1/16"
Work Height: 39-9/16"

Open Station

Throat depth 11-3/16"
Stroke 1-1/4"
Work Height 34-1/2"

Angle Shear

3" x 3" x 3/8"
4" x 4" x 1/4"
Work Height 39-7/8"

Flat Bar Shear

3/8" x 14"
1/2" x 12"
3/4" x 4"
Work Height 34-1/2"

Motor

5 HP, 1 or 3 phase, 208V-575V

Dimensions

44-3/8"w x 36-1/8"d x 55-1/4"h, 2,480 lb



60 TON – OUR BEST VALUE

4 Workstations – Maximum capacity: 1" diameter in 3/4" plate

Punching Station

Throat depth: 8-7/8"
Stroke: 6-7/8"
Largest Standard Punch: 1-1/16"
Work Height: 36-9/16"

Angle Shear

3" x 3" x 1/2"
4" x 4" x 3/8"
Work Height 39-7/8"

Flat Bar Shear

3/8" x 14"
1/2" x 12"
3/4" x 4"
Work Height 34-1/2"

Coper Notcher

Max. Capacity 2-1/2" x 4" x 3/8"
Work Height 39-1/2"

Motor

5 HP, 1 or 3 phase, 208V-575V.

Dimensions

46-1/8"w x 36-1/8"d x 56-1/8"h, 2,550 lb



55 Ton and 60 Ton Ironworker

65 Ton and 75 Ton Ironworker

65 TON – OUR MOST VERSATILE

5 Workstations – Maximum capacity: 1-1/16" diameter in 3/4" plate

Punching Station

Throat depth: 9-3/4"
Stroke: 1-13/16"
Largest Standard Punch: 1-1/16"
Work Height: 36-9/16"

Open Cavity

Height 8-3/4"
Width 12"
Work Height 43-1/2"

Angle Shear

5" x 5" x 3/8"
Work Height 43-1/2"

Flat Bar Shear

3/8" x 24"
1/2" x 14"
1" X 4"
Work Height 34-1/2"

Coper Notcher

Max. Capacity 2-1/2" x 5" x 3/8"
Work Height 39-1/2"

Motor

5-7.5 HP, 1 or 3 phase, 208V-575V

Dimensions

62-1/8"w x 45"d x 57"h, 4,750 lb



75 TON – THE SHOP STANDARD

4 Workstations – Maximum capacity: 1-1/16" diameter in 7/8" plate

Punching Station

Throat depth: 10"
Stroke: 1-13/16"
Largest Standard Punch: 1-1/16"
Work Height: 39-1/16"

Angle Shear

5" x 5" x 1/2"
Work Height 43-15/16"

Flat Bar Shear

1/2" x 14"
3/4" x 10"
Work Height 37"

Coper Notcher

Max. Capacity 2-1/2" x 5" x 1/2"
Work Height 42"

Motor

5-7.5 HP, 1 or 3 phase, 208V-575V

Dimensions

50"w x 45"d x 60-1/4"h, 4,100 lb





100 Ton and 100 Ton Deluxe

100 TON – THE WORKHORSE

4 Workstations – Maximum capacity: 1-1/16" diameter in 1" plate

Punching Station

Throat depth: 11"
Stroke: 1-13/16"
Largest Standard Punch: 1-1/16"
Work Height: 39-1/16"

Open Station

Throat depth: 14-3/4"
Stroke: 1-13/16"
Work Height 37"

Angle Shear

6" x 6" x 1/2"
Work Height 43-15/16"

Flat Bar Shear

3/4" x 14"
1" x 10"
Work Height 37"

Motor

5-7.5 HP, 1 or 3 phase, 208V-575V

Dimensions

56-1/8"w x 45"d x 61-11/16"h, 4,650 lb



100 TON DELUXE – IDEAL FOR THE LARGE SHOP

5 Workstations – Maximum capacity: 1-1/16" diameter in 1" plate

Punching Station

Throat depth: 11"
Stroke: 1-15/16"
Largest Standard Punch: 1-1/16"
Work Height: 39-3/8"

Angle Shear

6" x 6" x 1/2"
Work Height 43-15/16"

Flat Bar Shear

1/2" x 18"
3/4" x 14"
1" x 10"
Work Height 37"

Rod Shear

up to 1-1/2" round
up to 1-1/4" square
Work Height 54-1/2"

Coper Notcher

Max. Capacity 2-1/2" x 6" x 1/2"
Work Height 42"

Motor

10 HP, 1 or 3 phase, 208V-575V

Dimensions

56"w x 45-1/2"d x 63-1/8"h, 5,180 lb



100 Ton and 100 Ton Deluxe

120 Ton Ironworker & Hydraulic Power

120 TON – THE POWERHOUSE

5 Workstations – Maximum capacity: 1-1/2" diameter in 1" plate

Punching Station

Throat depth: 11"
Stroke: 2-1/8"
Largest Standard Punch: 1-1/16"
Work Height: 36-5/8"

Open Cavity

Height: 9"
Width: 11-3/4"
Work Height: 51-3/4"

Angle Shear

6" x 6" x 1/2"
Work Height 52-1/2"

Flat Bar Shear

1/2" x 24"
1" x 12"
Work Height 33-1/4"

Coper Notcher

Max. Capacity 3" x 6" x 1/2"
Work Height 40"

Motor

10 HP, 1 or 3 phase, 208V-575V

Dimensions

60"w x 60"d x 79-3/8"h, 5,500 lb



HYDRAULIC POWER

Factory Installed Hydraulic Accessory Pack



Use to power:

- 10 Ton Pipe/Tube Bender
- 20 or 40 Ton Shop Press
- Horizontal Press
- Radius Roller

Porta Power (may be ordered separately)



- Quickly connects to Hydraulic Accessories
- 5HP, 3 Phase, 208/230V, 14 amp
- 5HP, 3 Phase, 460V or 575V, 7 amp
- 5HP, 1 Phase, 230V, 26 amp

All of our ironworkers feature multiple workstations, allowing you to outfit your machine with a variety of optional attachments. This enables you to go from one operation to another without time-consuming tooling changes.



Ironworker Accessories

HYDRAULIC ACCESSORIES

20 Ton Shop Press



- 10-1/2" x 20" working area
- 6-1/4" stroke
- 37"h x 27"w x 24"d

40 Ton Shop Press



- 38" x 40-1/2" working area
- 12-1/4" stroke
- 79"h x 48"w x 48"d

10 Ton Pipe and Tube Bender

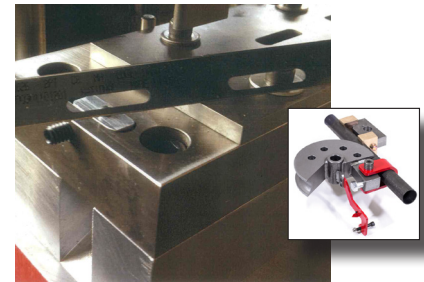

- 180° Bend Capacity
- up to 2" ID Schedule 40 Pipe
- 2-1/2" OD Tube
- 2" Square Tube
- 14" Stroke
- 40-1/2"h x 36-1/2"w x 42"d

Radius Roller



- Rolls medium to heavy flat, angle, pipe, tube and channel sections.
- Horizontal or Vertical operation
- 43"h x 45"w x 49"d

Horizontal Press



- Form, break or straighten mild steel with 20 Tons of power
- 10" Stroke
- 38-40" work height
- 24" x 42" table

Ironworker Accessories

Ironworker Accessories

PUNCH • SHEAR • COPE • NOTCH • BEND

Toolpack-1



14 sets of 219 punches and 413 dies
1/4" to 1-1/16" in 1/16" increments

Toolpack-2



8 sets of 228 punches and 419 dies

Oversized Punching Attachments

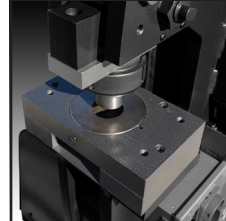

Oversized attachment
up to 1-1/2" round
Oversized attachment (shown)
up to 4" round

Magnetic Accessory Light



Connects to the Ironworker to provide task lighting

Rod Shear

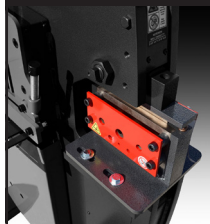

Reduce deformation in 1/4" to 1" mild steel rod

Multi-Shear

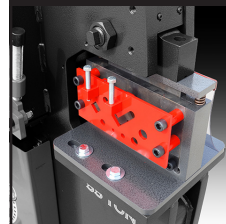

Combined Flat Bar, Angle, and Rod Shear for mild steel

Press Brake

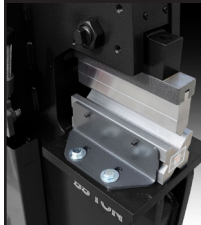

Controlled, repeatable bends in 1/4" thick mild steel

Pipe Notcher Housing

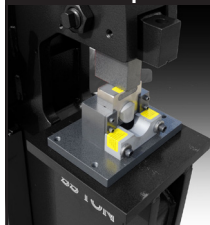

Notch Up to 2" OD Pipe Schedule 40 pipe (requires dies)

Pipe Notcher Dies



Standard dies sizes up to 2" OD Schedule 40 pipe

Turret Pipe Notcher Housing



Load 3 different pipe notcher dies at once and quickly switch from one size to the next Up to 2" OD Schedule 40 pipe (requires dies)

Angle Notcher

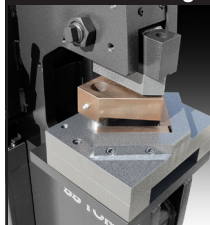

Precise 92° Notch in 1/4" mild steel

Coper Notcher

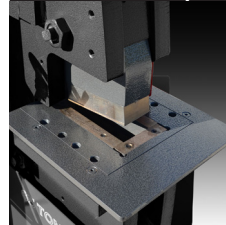

Precisely notch plate or angle up to 2" mild steel

Auto Cut



Adjustable proximity switch automates production when cutting repeatable lengths

Custom Tooling

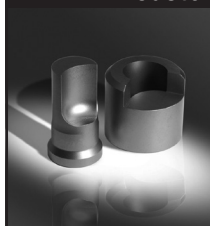

We can manufacture your custom tool, whether it's a modification to a stock punch or a custom die set.



Scan to view our Ironworkers on our website

All of our ironworkers feature multiple workstations, allowing you to outfit your machine with a variety of optional attachments. This enables you to go from one operation to another without time-consuming tooling changes.



Contract Manufacturing Services

With over 100 years experience in the metalworking marketplace, Cleveland Steel Tool is your ideal manufacturing partner. We specialize in rapid turnaround, and can inventory finished or semi-finished components. Small or large lot sizes, custom design or mass customization, our ISO-9001-2008 certified shop will exceed your expectations. We'll take your toughest jobs off your hands—whether you are working in steel, aluminum or bronze—we can help.

A New Jersey Automotive Supplier needed stainless brackets in various sizes.

CST sources the stainless steel and fabricated finished parts in each size with rounded corners and two bolt holes.



A Distributor of pneumatic and hand tools needed a domestic supplier of replacement blades for pneumatic and hand cutting tools.

CST produces a finished blade and stocks tools locally which reduced lead times by months and improved inventory turns and communication as well.



A Gear Manufacturer was seeking a supplier of gear blanks.

CST provides the finished gear blank and the only remaining operation for the manufacturer is to cut the teeth and heat treat.



A Supplier in the truck industry sought bushings for their high volume production equipment.

CST sources the bronze, machines it to exact customer specifications, and holds a backup inventory for rapid turnaround.



Contract Manufacturing Services



ISO 9001
Quality

Visit clevelandsteeltool.com for promotions, new items, updates and the latest news.



CLEVELAND STEEL TOOL

474 East 105th Street
Cleveland, OH 44108-1378 USA
800.446.4402 • 216.681.7400
Fax 216.681.7009
www.clevelandsteeltool.com

